

讓中國裝備技術與世界同步
WE WALK ALONGSIDE THE WORLD

Stock code:300415

Designed by Yizumi in February 2021

YIZUMI 伊之密

A5

A5標準型高端伺服注塑機

A5 Series Standard High-end Servo Injection Molding Machine

一樣的傑出不一樣的A5
New A5, Excellent As Always

广东伊之密精密注压科技有限公司

Guangdong Yizumi Precision Injection Molding and Die Casting Technology Co., Ltd.

Address: No.12, Shunchang Road, Daliang, Shunde, Foshan, Guangdong Province, China 528306
TEL:86-757-2921 9800 86-757-2926 5150(overseas) www.yizumi.com

Disclaimer:

- 1.We reserve the right to change specifications without prior notice.
- 2.The pictures are only for reference, please refer to the real object.
- 3.Data above come from Yizumi lab, available for reference.



伊之密公司簡介

立志成為所在領域世界級企業



伊之密順德容桂總部
Yizumi's headquarters in Ronggui, Shunde



順德五沙生產基地
Wusha production base in Shunde



蘇州吳江生產基地
Wujiang production base in Suzhou

輕合金及高分子複合材料模型成型工藝的廣泛應用，改變了近代的工業製造模式，使低成本大批量生產成為可能。今天，以鋁、鎂、鋅為代表的輕合金，及以塑膠、橡膠為代表的高分子複合材料，已成為工業製品和消費產品不可或缺的重要組成原料，從而帶動相關的模壓成型裝備的飛速發展。

2002年，公司在佛山市順德區容桂鎮四基生產出第一台伊之密塑膠注射成型機，隨後，伊之密相繼推出鋁、鎂、鋅合金壓鑄機、橡膠注射機和機器人自動化集成系統，並得到了越來越多模壓成型行業知名客戶的認可和信賴。現在，在中國市場，伊之密注塑機已經位列業內前三名，壓鑄機、橡膠機均位列行業前二。

2015年1月23日，伊之密成功登錄深交所A股市場，開啟企業發展的新征程。13年來，伊之密一直致力於讓中國裝備技術與世界同步，著力提高自身的技術實力、產品品質和服務。上市後，伊之密繼續朝著這個方向努力，鎖定“成為所在領域的世界級企業”的新目標，圍繞模壓成型專用機械設備領域多元化地延伸產品，創新產品研發和企業運營方式，積極佈局全球市場，最終讓全球的客戶和同行都認可伊之密的產品和品牌。

今天，伊之密除了擁有占地8000m²的順德高新區生產基地外，順德五沙生產基地（占地81117m²）和蘇州吳江生產基地（一期占地33213m²）已全面投產，滿足伊之密未來五到十年的發展需要。另外，伊之密在全球市場運行“伊之密”和“HPM”雙品牌戰略，在北美、印度設立生產基地，開拓和鞏固伊之密的國外市場。

為進一步把產品做到精益求精，伊之密引入IPD產品集成研發管理模式，從客戶需求出發，以嚴謹的流程開發產品，完善產品升級換代。投入累計超過1.2億元人民幣，打造屬於伊之密自己的精密製造平臺，並投資建設恒溫計量檢測中心，全力升級產品品質。

為客戶創造更大價值及最佳的投資回報，是我們存在的意義。今後，我們將在節能技術、自動化技術、精密控制技術、產品無故障技術等領域作更大投入，持續保證產品的先進性和可靠性。同時，我們還將致力建設業內更佳服務體系，提供快速、準確的服務，為提高全球客戶競爭力不懈努力。

About Yizumi

We aspire to become a world-class enterprise in our field!

With the widespread application of compression molding technology of light alloy and polymer-based composite, the mode of modern industrial manufacture has been changed and massive production with low-cost becomes possible. Today, light alloy exemplified by aluminum, magnesium and zinc, and polymer composites represented by plastics and rubber have become indispensable raw materials of industrial and consumer products. The relevant molding machinery industry thus achieves rapid development.

At the beginning of 2002, Yizumi manufactured the first injection molding machine in Siji, Ronggui Subdistrict. Then Yizumi launched die casting machines for aluminum, magnesium and zinc alloy, rubber injection machines and robotic automated integrated systems, obtaining high recognition from more and more well-known customers in the molding industry. Yizumi ranks top three among Chinese injection molding machine manufacturers and top two among both Chinese die casting machine manufacturers and rubber injection machine manufacturers.

On January 23, 2015, Yizumi successfully launched an IPO on the A-share market of Shenzhen Stock Exchange, which was a new start for the company's development. Yizumi has been committed to improve Chinese equipment technology to walk alongside the world and enhance its technical strength, product quality and service for 13 years. Yizumi will keep forward as always, set the new goal as becoming a world-class enterprise in the industry, diversify the products around the area of molding machinery for special applications, make innovations in the research and development of products as well as enterprise operation, so that Yizumi's products and brands are recognized by customers and counterparts worldwide.

In addition to the manufacturing base that covers an area of 80,000m² in Shunde National Hi-tech Industrial Zone, Yizumi's Wusha Factory (covering 81,117m²) and Suzhou factory (1st stage land area of 33,213m²) also have been put into use, which will meet the development needs of Yizumi in the next five to ten years. Yizumi also implements the YIZUM-HPM dual brand strategy in global markets and builds overseas bases in North America and India to develop and consolidate foreign markets.

To further improve the products, Yizumi introduces IPD mode to develop the products following strict procedures and upgrade the products based on customer needs. Yizumi has spent over 120 million RMB building its own precision manufacturing platform and invested in building a constant-temperature measuring and testing center to fully improve the product quality.

The greatest significance of Yizumi's existence lies in creating more value and better investment return for customers. In the future, the company will devote more input to areas such as technology of energy-saving, automation, precision control and trouble-free products so as to make sure our products are advanced and reliable. Meanwhile, we will be dedicated to setting up the better service system in the industry to provide rapid and quality service, making unremitting endeavor to improve the competitiveness of customers worldwide.

宗旨：我們致力於讓中國裝備技術與世界同步，並為全球客戶創造最佳的投資回報和客戶體驗。

使命：五年內成為中國領先的裝備製造商，並于主要新興市場建立全球經營系統，成為真正的“全球化”企業。

願景：成為一家經營好、管理好、文化好、讓員工引以為傲，為社會仰慕及尊敬的企業，永續經營。

Aim: We are dedicated in providing global clients with better investment return and customer experience.

Mission: We are determined to become a leading Chinese machine manufacturer in five years and a real globalized enterprise with establishment of global business system in major rising markets.

Vision: We wish to become a long-lasting enterprise with effective operation, efficient management and excellent culture, of which the employees are proud and to which social respect are showed.

A5標準型高端伺服注塑機 機型: 60T-560T

五大客户价值主张





繼伺服機成功推向市場多年, 在吸收了伊之密收購HPM的先進歐美技術後, 經過兩年多的市場調研, 充分了解客戶的“痛”和需求後, 採用IPD模式全新打造的一款標準型高端伺服注塑機。其為客戶創造的五大核心價值包括:

-  適用範圍廣
-  精密穩定
-  可靠耐用
-  高效節能
-  人性化

A5 Series Standard High-end Servo Injection Molding Machine Machine model: 60T-560T

Five Value Propositions

After successfully bringing servo machines to the market for years, mastering advanced European and American technology from HPM Company and completely understanding customer needs through over-two-year market research, Yizumi develops a brand-new standard high-end servo injection molding machine, A5 Series, based on IPD mode. A5 Series creates five core values for customers including:

-  Wide range of application
-  Precise and stable
-  Reliable and durable
-  High-efficiency and energy-saving
-  User-friendly



適用範圍廣
Wide range of application

- 更大的規格參數
- 更強的動力和更快的響應速度
- 用戶可獲得更寬的加工範圍降低重複投資成本

精密穩定
Precise and stable

- 全面優化注射機構確保注射的精確性和穩定性

可靠耐用
Reliable and durable

- 整機剛性綜合加強
- 採用均應力壓模技術
- 機器運作更加穩定可靠耐用

高效節能
High-efficiency and energy-saving

- 搭載第三代伺服系統
- 整機動作噪音低、動力強、回應快

人性化
User-friendly

- 友好的人機界面
- 集成大量常用功能軟體
- 提高可操作性和可維護性, 讓客戶用得自由舒暢

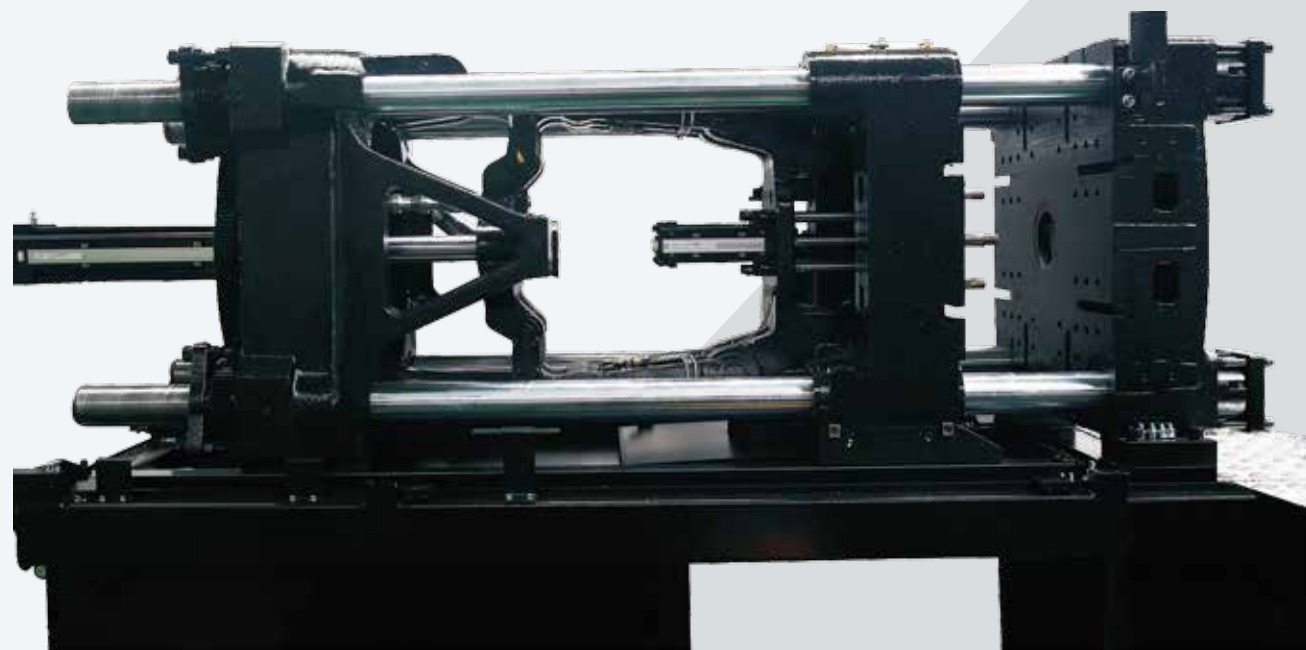

鎖模單元 Clamping Unit

客戶需求:鎖模機構可靠耐用, 模具保護功能有效、開模位置重複精度高

Customer need: reliable and durable clamping unit, effective mold protection and high repeatability of mold open position.

解決方案:基於現有成熟的鎖模機構, 經過深入研究提出12項關鍵的元素進行優化、創新, 其中包括:

Solutions: Based on mature structure of clamping unit, 12 key functions were optimized and innovated, including:

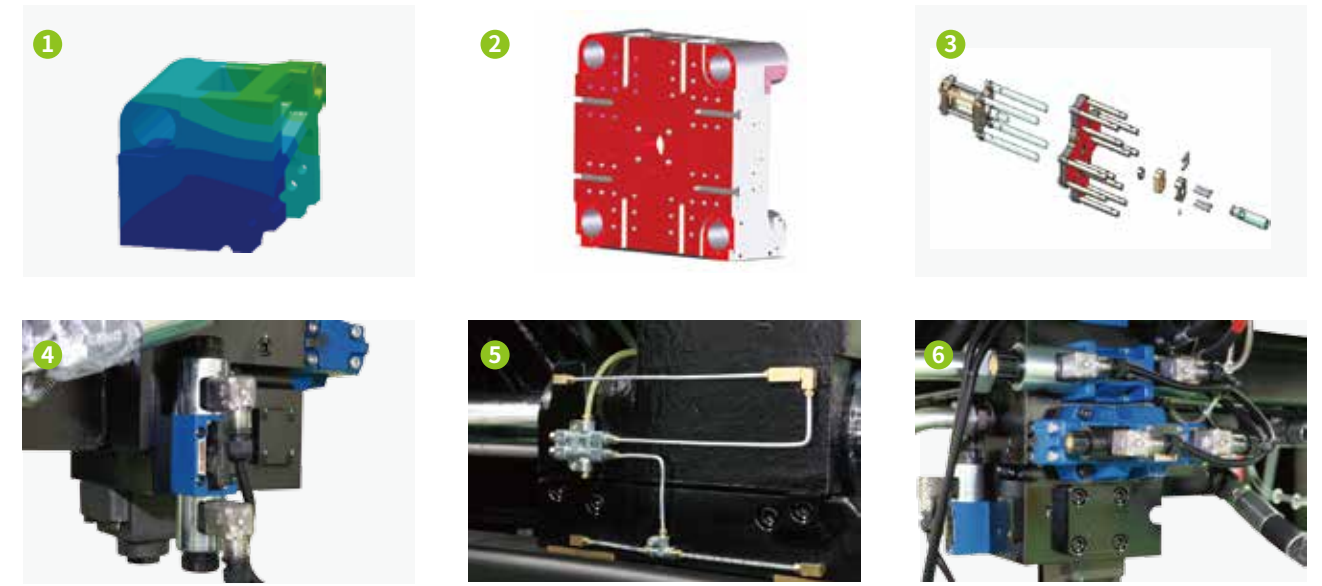

1 均應力壓模技術

均應力壓模技術, 鎖模力分佈平均, 模板變形小, 使用較低鎖模力, 生產同樣產品也不會產生成型問題, 同時保護模板和模具。

Uniform-stress molding technology

The clamping force is evenly distributed with little deformation of platen. No injection molding defect will be caused when the same part is produced under lower clamping force, which protects the platen and mold.

2 高剛性的T型槽模板

全系列模板高剛性設計, 鎖模單元整體剛性提升30%; 全系列標配T型槽, 方便裝卸模具, 降低因螺孔長期使用牙損機率, 提升模板使用壽命。

High-rigidity T-slot platen

High-rigidity T-slot platen is standard on the product line, which increases the overall rigidity of clamping unit by 30%, brings convenience for installation and removal of mold, reduces the wear of thread due to long-term use of screw hole and extends the life of platen.

3 頂針強制復位

標配頂針強制復位, 滿足特殊模具強制復位要求, 模具適用範圍更廣。

Compulsory ejector return

This function meets the requirement of special mold reset and the molds are more applicable.

4 開模位置閉環控制

開模位置定位精度及重複精度提升, 滿足機械手精確取出, 有利自動化持續生產。定位精度 $<2\text{mm}$, 重複精度 $<0.3\text{mm}$ 。

Closed-loop control of mold open position

The enhanced accuracy and repeatability of mold open position result in accurate part removal by robot and benefit automated continuous production. The mold open position accuracy is smaller than 2mm and repeatability is below 0.3mm.

5 獨特防傾滑腳設計

採用獨特防傾滑腳設計, 提升運動的平穩性, 降低摩擦力, 提升運動效率降低能耗, 同時避免模板傾斜保護模具。

Anti-tilt platen support design

Special anti-tilt platen support design increases the smoothness of motion, lowers friction, improves the efficiency of motion, reduces energy consumption and prevents the platen from tilting so as to protect the mold.

6 低壓模保功能

配置低壓模具保護控制單元, 確保模具的有效保護。

Low pressure mold protection

Low-pressure mold protection control unit ensures the mold gets effectively protected.

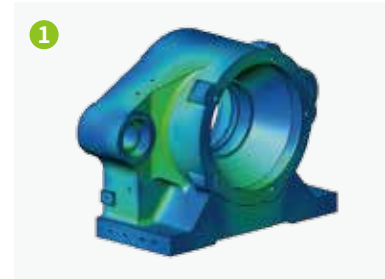

1 高剛性射膠模板
High-rigidity injection component



2 標配線性導軌支座
Injection unit support with linear guide rails



3 水平雙射移設計
Horizontal double-carriage design



4 新一代螺桿料管組
New screw & barrel unit



5 人性化設計：移動料斗滑軌
(320T 及以下)
User-friendly design: movable hopper rails (60T-320T)



5 集中潤滑模塊
Centralized lubrication module

注射單元 Injection Unit

客戶需求：射膠精密穩定、塑化和混色效果好

Customer need: high injection precision stability and improved quality of plasticizing and color mixing.

解決方案：基於現有成熟的射膠機械，提煉15項重要相關點進行優化、創新，其中包括：

Solutions: Based on mature structure of injection unit, 15 key functions were optimized and innovated, including:

1 優化注射單元

注射機構優化設計，提升注射剛性，並確保機構運動受力方向和射膠受力同軸，降低阻力，提高注射的穩定性和精度。

Optimized injection unit

The injection unit is optimized to increase rigidity, ensure coaxiality of the forces on motion and injection, reduce resistance, and enhance the stability and accuracy of injection.

2 整體式線軌結構

注射系統採用線軌結構，線軌配整體式射台支撐，射台移動摩擦力極小，提高注射精度，提升塑化效率。

Integrated linear guide rail structure

The injection unit is equipped with the one-piece supporting base which is integrated with linear guide rails, which minimizes the friction to motion, increases injection accuracy and enhances plasticizing efficiency.

3 水平雙射移設計

採用水平雙射移設計，雙缸平行注射，能有效消除注射機構翻轉力矩，確保注射穩定可靠。

Horizontal dual-carriage design

Adopt a horizontal dual-carriage design for two-cylinder parallel injection, effectively eliminating rotary torque to ensure a reliable and stable injection.

4 新一代通用型螺桿料管組

搭配新一代升級螺桿料管組件，進一步提升混色質量的同時提升塑化速度，還具有易換色、易清洗、低剪切不升溫等優點，具有良好的綜合性能，適用性更強。

New universal screw and barrel unit

The upgraded screw and barrel unit further optimizes color mixing and plasticizing efficiency. It has the advantages of easy color change and cleaning, low shear without temperature rise and wider applicability, etc.

5 人性化設計

採用人性化設計，包括電熱護罩、料斗滑軌、射嘴防護罩、集中潤滑等多項設計，在保護操作安全的同時，降低勞動強度，提高操作和維護方便性。

User-friendly designs

Heating device guard, hopper slide rail, purge guard and centralized lubrication, etc. are user-friendly designs that ensure the operation safety, reduce labor intensity and offer more ease of operation and maintenance.

液壓系統 Hydraulic System

伊之密第三代伺服節能技術 Yizumi's third-generation energy-saving servo technology

第三代伺服系統從電機內部結構和磁鋼的要求及油泵的選型和驅動軟體的開發均作了系統的改進優化，實現穩定、可靠、耐用、節能、高效、低噪音等極佳功能，比傳統液壓機節電約30%~80%。新增液壓油溫閉環控制功能，實現油溫控制精度±0.5°C以內，穩定性進一步提升。

The third-generation servo system has been improved and optimized in the internal structure of motor, the standard of magnetic steel, the selection of oil pump and the development of drive software to achieve superior performance in stability, reliability, durability, energy conservation, efficiency and low noise; the servo system uses 30%-80% less energy than conventional hydraulic machines. The accuracy of closed-loop hydraulic oil temperature control, which is the new function, is ±0.5°C with further increased stability.



專業品牌電機
Professional brand-name motor



進口品牌高壓齒輪泵
Imported high-pressure gear pump



匯川伺服驅動器
INOVANCE servo drive

多年市場應用驗證，更佳組合配置，系統穩定，可靠耐用，並具有高效、節能、低噪音、動力強、響應快等特性。

Proven by years of practical application and higher configured, the third-generation servo system is stable, reliable and durable and characterized by high efficiency, energy saving, low noise, strong power and fast response.

低噪音 Low noise

生產同一產品，在相同的工况下，第三代伺服系統，相對第二代伺服系統噪音降低約20%

Under the same working conditions, the 3rd-generation servo system emits 20% lower noise than the previous generation when producing the same product.

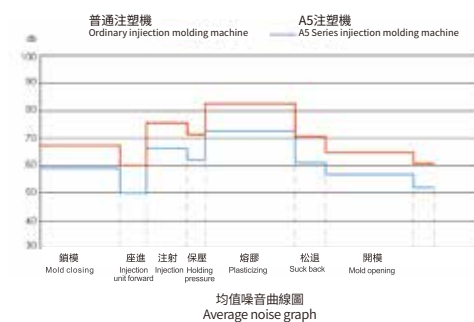

動力強 Strong power

動力系統功率配置充足，超載能力強勁，以120T為例，全速全壓測試可實現5分鐘不超載報警的極限測試。

The servo system has sufficient power and strong overload capacity, for example, a 120T machine in A5 Series can raise no overload alarm at maximum speed and under maximum pressure for 5 minutes in a test.



響應快 Fast response

系統響應速度進一步提升，相對二代伺服系統提升一個檔次，以120T為例，系統響應時間約40ms。

The speed of response is further upgraded. Take a 120T machine for example, the response time of servo system is about 40ms.

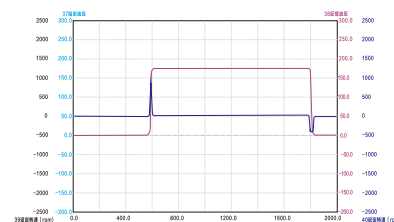

電控系統 Electrical System

盟立MK500控制系統：提升機器控制性能，製品更加穩定，整機穩定性更強。

Mirle MK500 control system delivers better performance in machine control and adds to the stability of product and machine.



- CANopen總線代替原有壓力流量模擬量傳送模式，傳輸更穩定，控制更精準
 - 10.4吋800×600 TFT LCD顯示，獨立32 bits CPU控制
 - 控制單元CPU採用Cortex A8，掃描週期達0.5ms，響應速度快，控制精度高
 - 240組模具參數存儲，帶USB接口可無限擴展存儲空間
 - 7+1組PID獨立CPU溫度控制，支持J、K型熱電偶切換；溫度控制使用PID自動調節功能，提高控制精度
 - 可擴展熱流道接口，最大支持60組熱流道並支持J、K型熱電偶切換（特工選配）
 - 品質監控管理，主要工藝參數曲線顯示和列表統計
 - 輸出、輸入點擴展功能，最大支持64點輸出、64點輸入（特工選配）
 - 內置常用軟件功能，能滿足多種不同的模具成型工藝
 - 支持常用通訊接口RS-232\485、CANOPEN、OPC UA（需擴展）
- CANopen bus technology makes transmission more stable and control more accurate.
 - 10.4-inch 800×600 TFT LCD with separate control by 32-bit CPU.
 - The control unit adopts Cortex-A8 processor with scan time of 0.5ms, speedy response and accurate control.
 - 240 sets of mold data memory, USB port for extension of storage.
 - 7+1 sections of PID temperature control supports switchover between type J and type K thermocouples. Automatic PID tuning improves the temperature control accuracy.
 - Expansion of hot runner interface is available, supporting 60 sets of hot runner and switchover between type J and type K thermocouples (optional).
 - Production quality control, with display of process parameter graphs and statistics tables.
 - The I/O module has 64 outputs and 64 inputs at maximum (optional).
 - Integration of common software meets different injection molding process requirements.
 - Common communication interface, including RS-232\485, CANOPEN, OPC UA (expand as needed).

標配數控背壓 Standard CNC back pressure

採用數控背壓方式，可更方便調整熔膠背壓。

Use CNC back pressure for easier adjustments of plasticizing back pressure.



人性化設計 User-friendly design

人工學設計的可旋轉式電腦掛箱，採用獨特的外觀設計，美觀、大方、操作舒適；電箱等部件設計既考慮了走線的安全，同時也提升了操作和維護的方便性。

The ergonomic rotary controller cabinet has a special and nice exterior design while offering comfort during use. The design of electrical cabinet and other components ensures safety of wiring and also makes operation and maintenance easier.



電箱整潔安全易於維護
Electrical cabinet that is neat, safe and maintenance-friendly



各種接口通用標準化
Universal standardized interfaces and connectors

A5標準型高端伺服中大型注塑機 機型：650T-2600T

A5大機的研發背景 R&D background of A5 series medium to large tonnage machine

自2015年9月A5系列中小型(60T-480T)全面上市后,其“適用範圍廣、高效、精密穩定”的獨特差異化優勢已得到客戶廣泛認同和驗證,同時客戶需求的系列化亦要求A5產品線進一步延伸。經過大量走訪,調研客戶需求和“痛點”,最終確定650T以上的A5中大機系列的核心客戶價值為:可靠穩定。在此背景下,伊之密A5 IPD項目組順勢而為,在保證全系列產品線的優勢下,中大機著重研究并測試了其穩定可靠性和塑化要求,這與客戶的需求和實際的“痛點”高度吻合。

A5 series of small-medium machine (60T-480T) was introduced to market since Sept. in 2015. Its unique advantage of “wide range of application, high efficiency and precision stability” has been identified and verified by customers, and customers also request to extend existing A5 series. After interviewing, researching customers' needs, YIZUMI finally determined the core customer value of the A5 series medium-large machines (over 650T), which is reliability & stability. Under this background, YIZUMI IPD-program team follows the trend and focuses on research and test of medium-large injection molding machine in its reliability, stability and plasticizing performance, which completely meets customers needs.

High Standard A5 Series Medium To Large Tonnage Servo Injection Molding Machine

Machine model: 650T-2600T

在A5中大型產品線中,為確保“可靠穩定”的核心價值,我們重新定義并嚴格執行以下關鍵檢驗或性能指標:

- 逆流檢測偏差<1mm
- 熔膠重量偏差<0.5%
- 模板平行度(負載)<0.18mm (UN800A5)
- 模板平行度(開模至100mm)<0.54mm (UN800A5)
- 導柱受力偏差<±3%
- 鎖模力重複精度<1%
- 開模終點位置精度<2mm
- 静态温控精度<±1°C

To fulfill the core value of “reliability & stability” in A5 series medium-large machines, we redefine and strictly implement key inspection and performance criteria below:

- Backflow detection variation <1mm
- Plasticizing weight deviation <0.5%
- Platen parallelism (after load) <0.18mm (UN800A5)
- Platen parallelism (mold opening to 100mm) <0.54mm (UN800A5)
- Force deviation of tie bar <±3%
- Repeatability of clamping force <1%
- Accuracy of mold-open end position <2mm
- Static temperature control accuracy <±1°C





鎖模單元 Clamping Unit

鎖模機械結構——穩重、高剛性

Mechanical structure of clamping unit——stable, high-rigidity

模板結構採用歐洲風格設計、全面優化參數與受力分布，機架採用高剛性材料及制作工藝，確保整機紮實、穩定可靠。

The platen structure is designed with European style and fully optimized parameters and force distribution. High-rigidity materials and manufacturing processes for base frame ensure the machine is strong, stable and reliable.

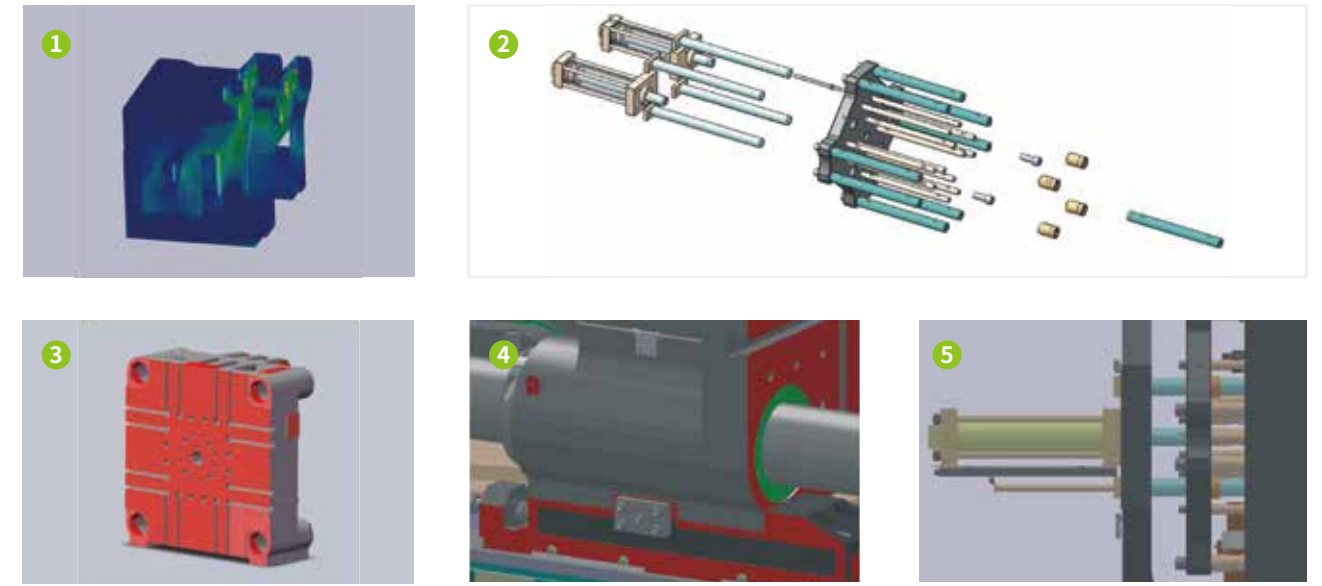

1 均應力壓模技術

鎖模力分佈平均，模板變形小；可使用較低鎖模力，生產同樣的產品不會發生飛邊，同時可保護模板和模具。

Uniform-stress clamping technology

Uniform distribution of clamping force, less platen deformation. Lower clamping force is applicable to produce the same part without flash, protecting platen and mould.

2 高剛性的T型槽模板

全系列模板高剛性設計，大大提升鎖模單元整體剛性；全系列標配T型槽，方便裝卸模具，降低因螺孔長期使用牙損機率，提升模板使用壽命。

High-rigidity T-slot platen

Full range of high-rigid plates greatly improve the overall rigidity of the clamping unit; The series is equipped with T-slotted plates to facilitate mold loading/unloading, reduce the rate of wear on screw hole threads after prolonged use and extend the useful life of platens.

3 頂針強制復位

標配頂針強制復位，滿足特殊模具強制復位要求，模具使用範圍更廣。

Compulsory ejector return

Standard ejector forced reset feature to fulfill the forced reset requirement for certain special molds and expand mold applications.

4 加長型設計滑腳

動模板採用前置型重載支撐滑腳，支撐重心向碼模面前置，避免模板傾斜，重型模具亦可運行平穩。

Extended moving platen support

The movable platen is equipped with front heavy-load sliding supports. The center of gravity of support moves forwards to the mold mounting surface, preventing the platen from tilting. Machine still operates steadily when it is loaded with heavy molds.

5 加長型頂針板導向設計

頂針板導向採用加長型設計，有效避免頂針板傾斜，提高頂針穩定性；頂出力均勻，頂出位置更準，機器頂出效果更佳。

Extended ejector guiding platen design

Ejector guiding extended, effectively avoiding ejector plate tilting and improving stability of ejection. Uniform distribution of ejector force, precise ejection position with better ejection performance.



注射單元 Injection Unit

射膠機械結構——穩定、少摩擦 Mechanical structure of injection unit—stable, less friction

射膠結構優化設計，提高注射的剛性；減少注射過程中的各項摩擦阻力，提高注射精度，確保注射的穩定性。
Optimized injection structure design improves rigidity of injection unit.
Reduce all frictional resistance during injection molding process enhance the stability & precision of injection.



整體式線軌支座 Integrated linear guide rail support

- 採用整體式線性導軌、水平雙射移設計，雙缸平行注射，確保注射穩定可靠；
- 整體式線軌支座，可減小射臺與線軌或導桿的摩擦力，成型制品的重複精度更高。
- Medium size machine adopts integrated linear guide rail, horizontal double-carriage design and double-cylinder injection to ensure injection is reliable & stable.
- Integrated linear guide rail support reduces the friction between injection unit and linear guide rail or tie bar and enhances production repeatability.



螺桿參數結構優化 Optimized plasticizing screw

- 進一步提升塑化效率10%-30%，同時提升塑化品質，改善混色效果。
- 配置四套標準料管組，適用範圍進一步擴展。
- The plasticizing efficiency is up by 10%-30% and the quality of plasticizing and color mixing is improved as well.
- Four sets of standard barrel assembly are available so that the machine has wider applicability.



標配熔膠比例背壓 Proportional plasticizing back pressure control

- 數控背壓方式可方便實現電腦精準控制，提高注射的穩定性。
- Proportional back pressure facilitates accurate control by industrial computer and enhances the stability of injection.

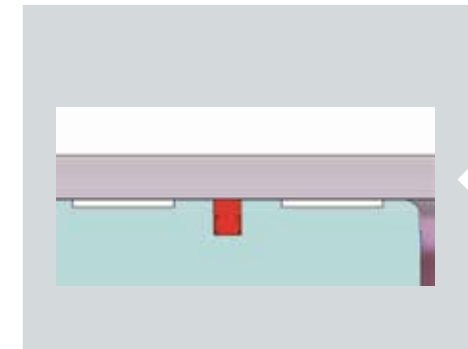

注射油缸採用低摩擦油封設計 Low friction oil seal inside injection cylinder

- 注射油缸採用低摩擦油封重載支撐環設計，充分減小射膠阻力，長期使用精度有保障。
- Injection cylinder adopts low friction oil seal design, fully reducing injection friction and ensuring longer service life.

液壓系統 Hydraulic System

伊之密第三代伺服節能技術 Yizumi's third-generation energy-saving servo technology

第三代伺服系統從電機內部結構和磁鋼的要求及油泵的選型和驅動軟體的開發均作了系統的改進優化，實現穩定、可靠、耐用、節能、高效、低噪音等極佳功能，比傳統液壓機節電約30%~80%。新增液壓油溫閉環控制功能，實現油溫控制精度±0.5°C以內，穩定性進一步提升。

The third-generation servo system has been improved and optimized in the internal structure of motor, the standard of magnetic steel, the selection of oil pump and the development of drive software to achieve superior performance in stability, reliability, durability, energy conservation, efficiency and low noise; the servo system uses 30%-80% less energy than conventional hydraulic machines. The accuracy of closed-loop hydraulic oil temperature control, which is the new function, is ±0.5°C with further increased stability.



專業品牌電機
Professional brand-name motor



進口品牌高壓齒輪泵
Imported high-pressure gear pump



匯川伺服驅動器
INOVANCE servo drive

多年市場應用驗證，更佳組合配置，系統穩定，可靠耐用，並具有高效、節能、低噪音、動力強、響應快等特性。

Proven by years of practical application and higher configured, the third-generation servo system is stable, reliable and durable and characterized by high efficiency, energy saving, low noise, strong power and fast response.

低噪音 Low noise

生產同一產品，在相同的工況下，第三代伺服系統，相對第二代伺服系統噪音降低約20%

Under the same working conditions, the 3rd-generation servo system emits 20% lower noise than the previous generation when producing the same product.

動力強 Strong power

動力系統功率配置充足，過載能力強勁，全速全壓測試可實現5分鐘不過載報警的極限測試

High efficiency gear pump realizes fast response injection molding which can be used in high-precision molding.

電控系統 Electrical System

高精度的控制系統——系統壓力、流量、位置和溫度控制更加準確，制品更加穩定，整機穩定更強。

High precision control system—more accurate control of system pressure, flow, position & temperature, higher part repeatability, as well as more stable overall machine performance.



升級KEBA系統 Upgraded KEBA system

- 可以擴展AO、AI、DO、DI、TM等多種多個模塊，滿足更多需求；
- 實時監測機器配置傳感器等信號，匹配相關動作，安全性更高；
- 支持常用通訊接口RS232/485，CANOPEN，以太網接口，溫度補償傳感器接口，USB接口。
- Expandable with multiple modules including AO, AI, DO, DI, and TM to meet more requirements;
- Real-time monitoring of signals from machine equipped sensors to coordinate corresponding movements for higher operating safety;
- Support common RS232/485 communication interface, CANOPEN, Ethernet port, temperature compensation sensor connector, and USB port.



開模比例閥減速回路 (650T-1000T) Proportional valve-controlled mold opening deceleration

- 縮短開模過衝量，提升開模位置重複精度。
- 滿足機械手精確抓取產品，提升自動化連續生產效率。
- Reduce excessive distance in mold opening and improve repeatability of mold-open position
- Facilitate accurate part removal by robot and improve the efficiency of automated production



低油位報警 Low oil level alarm

- 低油位自動報警功能，防止因油位過低吸入氣體而導致液壓回路不穩定。
- Automatic low oil level alarm function prevents gas from being sucked in due to low oil level, avoiding consequent instability of hydraulic circuit

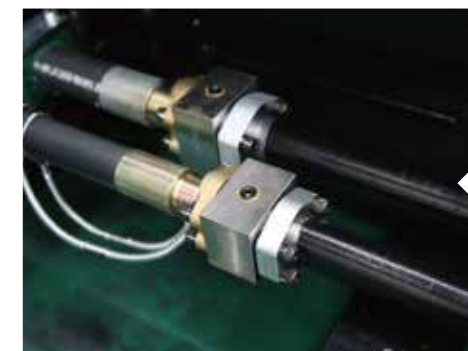

非焊接式主油管擴口設計 Weldless flared hydraulic hose design

- 確保長期使用不會出現焊縫開裂的漏油情況。
- Ensure no oil leaks due to cracked weld during long-term use

UN60A5~2600A5 技術參數表

Specifications of UN60A5 to UN2600A5

備註:正常情況下改善規格參數,恕不另行通知

Note:Due to improvement, specifications may be changed without prior notice.

說明		DESCRIPTION		UNIT	UN60A5	UN90A5	UN120A5	UN160A5	UN200A5									
國際標準規格		International size			190/600	295/900	420/1200	604/1600	895/2000									
射膠單元 INJECTION UNIT																		
					A	B	A	B	C	A	B	C	A	B	C			
理論注射容積		Shot volume		cm ³	51.3	71.7	116.6	158.7	207.3	163.6	246.9	307.6	297.7	371	452.3	425.2	518.5	664.4
實際注射量		Shot weight (PS)		g	47.2	65.9	107.3	146	190.8	150.5	227.1	283	273.9	341.3	416.1	391.2	477	611.3
				oz	1.7	2.3	3.8	5.2	6.7	5.3	8	10	9.7	12	14.7	13.8	16.8	21.6
螺桿直徑		Screw diameter		mm	22	26	30	35	40	35	43	48	43	48	53	48	53	60
注射壓力		Injection pressure		MPa	373	267	252.8	185.6	142.2	256.9	170	136.7	203	162.9	133.6	210.7	172.8	134.8
注射速率	標準伺服泵系統	Injection rate	Standard servo pump	g/s	43.0	60.1	69.6	94.7	123.7	83.2	125.6	156.5	132.2	164.8	200.9	148	182.6	231.5
	進口伺服泵系統(選配)		Imported servo pump (optional)		43.0	60.1	69.6	94.7	123.7	87	132	164	133	166	202	144	175	224
	變量泵系統(選配)		Variable-displacement pump (optional)		38.7	54.1	68.7	93.5	122	67.2	101.5	126.5	121.6	151.5	184.7	132	161	206.3
螺桿長度直徑比		Screw L:D ratio			20:1	20:1	24:1	20:1	20:1	24:1	20:1	20:1	22.3:1	20:1	20:1	22.:1	20:1	20:1
最大注射速度	標準伺服泵系統	Max. injection speed	Standard servo pump	mm/s	124		107		94		99		89					
	進口伺服泵系統(選配)		Imported servo pump (optional)		123		107		100		101		87					
	變量泵系統(選配)		Variable-displacement pump (optional)		110.8		106		76		91		79.3					
螺桿行程		Screw stroke		mm	135	165	170	205	235									
螺桿轉速	標準伺服泵系統	Screw speed (stepless)	Standard servo pump	r/min	0-217		0-198		0-208		0-235		0-194					
	進口伺服泵系統(選配)		Imported servo pump (optional)		0-230		0-219		0-242		0-255		0-190					
	變量泵系統(選配)		Variable-displacement pump (optional)		0-194		0-198		0-171		0-216		0-173					
鎖模單元 CLAMPING UNIT																		
鎖模力		Clamping force		kN	600	900	1200	1600	2000									
開模行程		Opening stroke		mm	260	330	360	420	490									
導柱內間距(WxH)		Space between tie bars (WxH)		mmxmm	310x310	360x360	410x410	460x460	530x530									
模板最大距離		Max. daylight		mm	590	710	810	940	1040									
容模量(最薄-最厚)		Mold thickness (min.-max.)		mm	120-330	130-380	145-450	160-520	180-550									
頂出行程		Ejector stroke		mm	60	100	120	140	150									
頂出孔數量		Number of ejector pin hole			1	5	5	5	5									
頂出力		Ejector force		kN	22	28	42	42	49									
動力/電熱 POWER UNIT																		
最大系統壓力		Max. system pressure		MPa	17.5	17.5	17.5	17.5	17.5									
油泵馬達	標準伺服泵系統	Oil pump motor	Standard servo pump	kW	11	11	15	25	25									
	進口伺服泵系統(選配)		Imported servo pump (optional)		8	9	13	15	17									
	變量泵系統(選配)		Variable-displacement pump (optional)		7.5	11	11	15	18.5									
電熱功率		Heating power		kW	4.8/5.5	6.9/7.8	9/10.1	10.9/12.1	14.4/16.8									
溫度控制區數		Number of temperature control zones			4	4	4	4	5									
其它 GENERAL																		
干循环时间		Dry cycle time		s	1.6	1.8	2.0	2.4	2.7									
油箱容量		Oil tank capacity		L	130	150	155	220	255									
外形尺寸(LxWxH)		Machine dimensions (LxWxH)		mxm	4.24×1.14×1.90	4.49×1.22×1.98	4.82×1.30×2.05	5.35×1.37×2.13	5.76×1.45×2.21									
设计重量		Machine weight		kg	2500	3100	3700	4600	5600									

說明		DESCRIPTION	UNIT	UN260A5			UN320A5			UN400A5			UN480A5		
國際標準規格		International size		1269/2600			1885/3200			2693/4000			3330/4800		
射膠單元 INJECTION UNIT															
				A	B	C	A	B	C	A	B	C	A	B	C
理論注射容積		Shot volume	cm ³	584.6	749.3	962.4	834.1	1071.3	1338.3	1198.5	1497	1828.8	1678.5	2050.5	2459.6
實際注射量		Shot weight (PS)	g	537.9	689.3	885.4	767.4	985.6	1231.2	1102.6	1377.3	1682.5	1544.2	1886.4	2262.8
			oz	19	24.3	31.2	27.1	34.8	43.4	38.9	48.6	59.3	54.5	66.5	79.8
螺桿直徑		Screw diameter	mm	53	60	68	60	68	76	68	76	84	76	84	92
注射壓力		Injection pressure	MPa	217.1	169.4	131.8	226.2	176.1	141	224.8	180	147.3	198.6	162.5	135.5
注射速率	標準伺服泵系統	Injection rate	Standard servo pump	160.3	205.5	264	238.8	306.7	383.1	297	371	453.8	379.8	464.0	556.5
	進口伺服泵系統(選配)		Imported servo pump (optional)	203	260	334	214	275	343	291	363	444	392	473	568
	變量泵系統(選配)		Variable-displacement pump (optional)	162.3	208.0	267.2	251	322.4	402.7	252.6	315.5	385.4	396.5	484.4	581
螺桿長度直徑比		Screw L:D ratio		22.6:1	20:1	20:1	22.6:1	20:1	20:1	22.3:1	20:1	20:1	22.1:1	20:1	20:1
最大注射速度	標準伺服泵系統	Max. injection speed	Standard servo pump	79			91			89			91		
	進口伺服泵系統(選配)		Imported servo pump (optional)	101			83			87			94		
	變量泵系統(選配)		Variable-displacement pump (optional)	80			96.5			75.6			95		
螺桿行程		Screw stroke	mm	265			295			330			370		
螺桿轉速	標準伺服泵系統	Screw speed (stepless)	Domestic servo pump (standard)	0-161			0-200			0-156			0-140		
	進口伺服泵系統(選配)		Imported servo pump (optional)	0-207			0-182			0-156			0-145		
	變量泵系統(選配)		Variable-displacement pump (optional)	0-164			0-212			0-132			0-147		
鎖模單元 CLAMPING UNIT															
鎖模力		Clamping force	kN	2600			3200			4000			4800		
開模行程		Opening stroke	mm	530			640			700			780		
導柱內間距(WxH)		Space between tie bars (WxH)	mmxmm	610x570			710x670			760x710			830x810		
模板最大距離		Max. daylight	mm	1140			1300			1430			1590		
容模量(最薄-最厚)		Mold thickness (min.-max.)	mm	195-610			220-660			240-730			260-810		
頂出行程		Ejector stroke	mm	160			170			210			220		
頂出孔數量		Number of ejector pin hole		13			13			13			17		
頂出力		Ejector force	kN	77			77			110			110		
動力/電熱 POWER UNIT															
最大系統壓力		Max. system pressure	MPa	17.5			17.5			17.5			17.5		
油泵馬達	標準伺服泵系統	Oil pump motor	Standard servo pump	30			51			60			70		
	進口伺服泵系統(選配)		Imported servo pump (optional)	28			31			31+9			31+17		
	變量泵系統(選配)		Variable-displacement pump (optional)	22			37			37			45		
電熱功率		Heating power	kW	16.6/19			22.2/24.6			26.4/30.9			33.1/36.2		
溫度控制區數		Number of temperature control zones		5			5			6			6		
其它 GENERAL															
干循环时间		Dry cycle time	s	2.8			3.2			4			4.5		
油箱容量		Oil tank capacity	L	335			445			570			760		
外形尺寸(LxWxH)		Machine dimensions (LxWxH)	mxm	6.24x1.64x2.39			6.96x1.85x2.50			7.73x2.16x2.45			8.47x2.16x2.49		
设计重量		Machine weight	kg	7600			10300			14700			17300		

UN60A5~2600A5 技術參數表
Specifications of UN60A5 to UN2600A5

備註:正常情況下改善規格參數,恕不另行通知
Note:Due to improvement, specifications may be changed without prior notice.

說明		DESCRIPTION	UNIT	UN560A5				UN650A5				UN800A5				UN1000A5							
國際標準規格		International size		3330/5600				4820/6500				6780/8000				9015/10000							
射膠單元 INJECTION UNIT																							
				A	B	C	D	A	B	C	D	A	B	C	D	A	B	C	D				
理論注射容積		Shot volume	cm ³	1678.5	2050.5	2459.6	2906.0	2216.7	2659	3141.6	3664.4	3190	3769.9	4397.2	5072.8	4319.7	5038.5	5812.6	6749.5				
實際注射量		Shot weight (PS)	g	1544.2	1886.4	2262.8	2673.5	2039.4	2446.3	2890.3	3371.2	2935.6	3468.3	4045.4	4667.0	3974.1	4635.4	5347.6	6209.5				
				oz	54.5	66.5	79.8	94.3	71.9	86.3	101.9	118.9	103.5	122.3	142.7	164.6	140.2	163.5	188.6	219.0			
螺桿直徑		Screw diameter	mm	76	84	92	100	84	92	100	108	92	100	108	116	100	108	116	125				
注射壓力		Injection pressure	MPa	198.6	162.5	135.5	114.6	217.6	181.4	153.5	131	212.8	180.2	154.5	133.9	208.8	179.1	155.2	133.6				
注射速率	標準伺服泵系統	Injection rate	g/s	Standard servo pump		379.8	464	556.5	658	443	531	629	699	563	666	777	896	642	749	864	1004		
	進口伺服泵系統(選配)			Imported servo pump (optional)		387	473	567	671	423	507	699	699	533	630	735	848	642	749	864	1004		
	變量泵系統(選配)			Variable-displacement pump (optional)		396.7	484.6	581.3	686.8	423	507.4	599.5	699.3	533.2	630	734.8	847.7	642.4	749.2	864.4	1003.7		
螺桿長度直徑比		Screw L:D ratio		22.1:1	20:1	22:1	20:1	21.9:1	22:1	21.6:1	20:1	21.7:1	22:1	21.5:1	20:1	21.6:1	22:1	21.6:1	20:1				
最大注射速度	標準伺服泵系統	Max. injection speed	mm/s	Standard servo pump				91				87				92				89			
	進口伺服泵系統(選配)			Imported servo pump (optional)				94				83				87				89			
	變量泵系統(選配)			Variable-displacement pump (optional)				95				83				87				89			
螺桿行程		Screw stroke	mm	370				400				480				550							
螺桿轉速	標準伺服泵系統	Screw speed (stepless)	r/min	Standard servo pump				0-140				0-143				0-143				0-116			
	進口伺服泵系統(選配)			Imported servo pump (optional)				0-145				0-143				0-136				0-116			
	變量泵系統(選配)			Variable-displacement pump (optional)				0-130				0-127				0-110				0-103			
鎖模單元 CLAMPING UNIT																							
鎖模力		Clamping force	kN	5600				6500				8000				10000							
開模行程		Opening stroke	mm	850				900				1040				1220							
導柱內間距(WxH)		Space between tie bars (WxH)	mmxmm	850x810				930x930				1000x1000				1160x1160							
模板最大距離		Max. daylight	mm	1700				1800				2040				2380							
容模量(最薄-最厚)		Mold thickness (min.-max.)	mm	330-850				350-900				400-1000				450-1160							
頂出行程		Ejector stroke	mm	220				280				280				320							
頂出孔數量		Number of ejector pin hole		17				21				21				21							
頂出力		Ejector force	kN	166				182				182				274							
動力/電熱 POWER UNIT																							
最大系統壓力		Max. system pressure	MPa	17.5				17.5				17.5				17.5							
油泵馬達	標準伺服泵系統	Oil pump motor	kW	Standard servo pump		70		34+51		51+60		60×2											
	進口伺服泵系統(選配)			Imported servo pump (optional)		31+17		31×2		31x2+17		31×3											
	變量泵系統(選配)			Variable-displacement pump (optional)		45		37+22		37×2		37+45											
電熱功率		Heating power	kW	33.1/43				38/47				42/51				46.5/63.6							
溫度控制區數		Number of temperature control zones		6				6				6				7							
其它 GENERAL																							
干循环时间		Dry cycle time	s	5.5				6.5				7				8							
油箱容量		Oil tank capacity	L	760				1000				1150				1300							
外形尺寸(LxWxH)		Machine dimensions (LxWxH)	mxm	8.73x2.16x2.49				9.57x2.25x2.66				10.51x2.38x2.73				11.37x2.60x2.66							
设计重量		Machine weight	kg	17800				24600				33700				42200							

UN60A5~2600A5 技術參數表
Specifications of UN60A5 to UN2600A5

備註:正常情況下改善規格參數,恕不另行通知
Note:Due to improvement, specifications may be changed without prior notice.

說明		DESCRIPTION	UNIT	UN1400A5				UN1800A5				UN2200A5				UN2600A5						
國際標準規格		International size		12053/14000				18471/18000				21215/22000				29880/26000						
射膠單元 INJECTION UNIT																						
				A	B	C	D	A	B	C	D	A	B	C	D	A	B	C				
理論注射容積		Shot volume	cm ³	6341.0	7363.1	8588.3	9907.8	10019.7	11559	13208.4	15888.6	12384.7	14151.9	16036.8	19085.2	17925.7	20313.3	24174.5				
實際注射量		Shot weight (PS)	g	5833.7	6774.1	7901.3	9115.2	9218.1	10634.4	12151.7	14617.5	11394.0	13019.7	14753.9	17558.3	16491.7	18688.3	22240.6				
				oz	205.8	238.9	278.7	321.5	325.2	375.1	428.6	515.6	401.9	459.2	520.4	619.3	581.7	659.2	784.5			
螺桿直徑		Screw diameter	mm	116	125	135	145	135	145	155	170	145	155	165	180	155	165	180				
注射壓力		Injection pressure	MPa	190.1	163.7	140.4	121.8	184.3	159.8	139.8	116.2	171.3	149.9	132.3	111.2	166.7	147.1	123.6				
注射速率	標準伺服泵系統	Injection rate	g/s	Standard servo pump		791	919	1071	1236	1092	1259	1439	1731	1316	1504	1704	2028	1803	2044	2432		
	進口伺服泵系統(選配)			Imported servo pump (optional)		-	-	-	-	-	-	-	-	-	-	-	-	-	-	-	-	
	變量泵系統(選配)			Variable-displacement pump (optional)		830.6	964.5	1125	1298	1157	1335	1525.6	1835	1361	1555.5	1762.7	2097.8	1803.3	2043.5	2431.9		
螺桿長度直徑比		Screw L:D ratio		22:1	20:1	20:1	22:1	23.6:1	22:1	20:1	22:1	23.5:1	22:1	20.6:1	22:1	23.4:1	22:1	20:1				
最大注射速度	標準伺服泵系統	Max. injection speed	mm/s	Standard servo pump				81				83				87				104		
	進口伺服泵系統(選配)			Imported servo pump (optional)				-				-				-				-		
	變量泵系統(選配)			Variable-displacement pump (optional)				85				88				90				104		
螺桿行程		Screw stroke	mm	600				700				750				950						
螺桿轉速	標準伺服泵系統	Screw speed (stepless)	r/min	Standard servo pump				0-106				0-110				0-100				0-116		
	進口伺服泵系統(選配)			Imported servo pump (optional)				-				-				-				-		
	變量泵系統(選配)			Variable-displacement pump (optional)				0-95				0-93				0-100				0-116		
鎖模單元 CLAMPING UNIT																						
鎖模力		Clamping force	kN	14000				18000				22000				26000						
開模行程		Opening stroke	mm	1350				1560				1750				1950						
導柱內間距(WxH)		Space between tie bars (WxH)	mmxmm	1310X1310				1560X1560				1850X1650				1950X1800						
模板最大距離		Max. daylight	mm	2700				3210				3570				3830						
容模量(最薄-最厚)		Mold thickness (min.-max.)	mm	600-1350				800-1650				850-1820				900-1880						
頂出行程		Ejector stroke	mm	380				400				430				430						
頂出孔數量		Number of ejector pin hole		29				33				33				33						
頂出力		Ejector force	kN	303				303				460				460						
動力/電熱 POWER UNIT																						
最大系統壓力		Max. system pressure	MPa	17.5				17.5				17.5				17.5						
油泵馬達	標準伺服泵系統	Oil pump motor	kW	Standard servo pump		70x2		60x3		70x3		70x4		70x4		70x4		70x4				
	進口伺服泵系統(選配)			Imported servo pump (optional)		-		-		-		-		-		-		-				
	變量泵系統(選配)			Variable-displacement pump (optional)		55x2		55x2+37		55x3		55x4		55x4		55x4		55x4				
電熱功率		Heating power	kW	65.6/69.9				95				106.6				126.1						
溫度控制區數		Number of temperature control zones		8				8				10				10						
其它 GENERAL																						
干循环时间		Dry cycle time	s	9.5				13				16.5				17						
油箱容量		Oil tank capacity	L	1600				1900				2000				2300						
外形尺寸(LxWxH)		Machine dimensions (LxWxH)	mxm	12.64x3.00x3.16				14.42x3.30x3.34				16.38x3.93x3.76				17.84x4.12x4.00						
设计重量		Machine weight	kg	75000				108000				145000				190000						

模板尺寸圖

Platen Dimensions

UN60A5

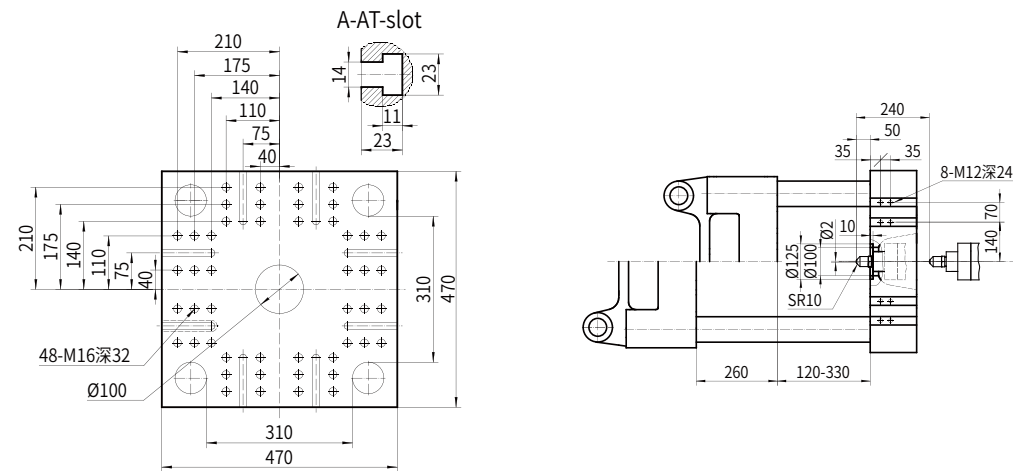

UN90A5

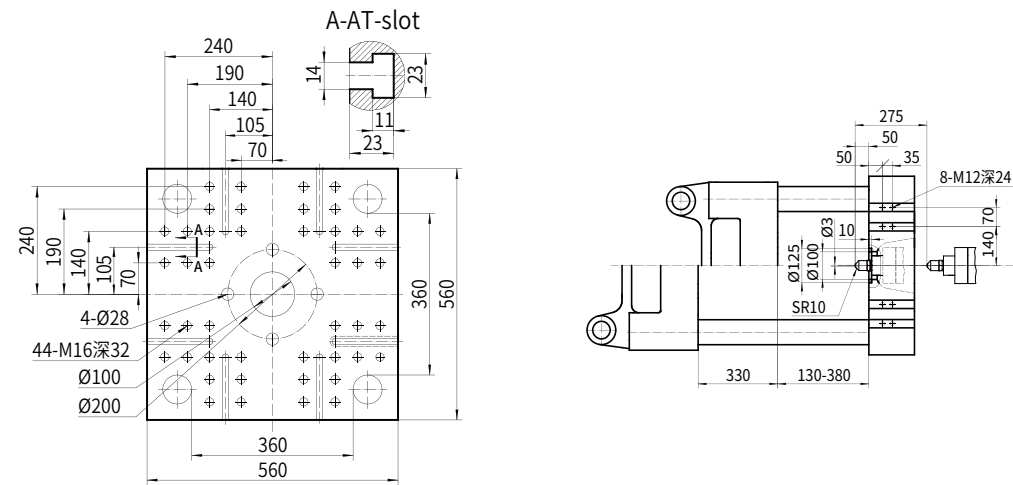

UN120A5

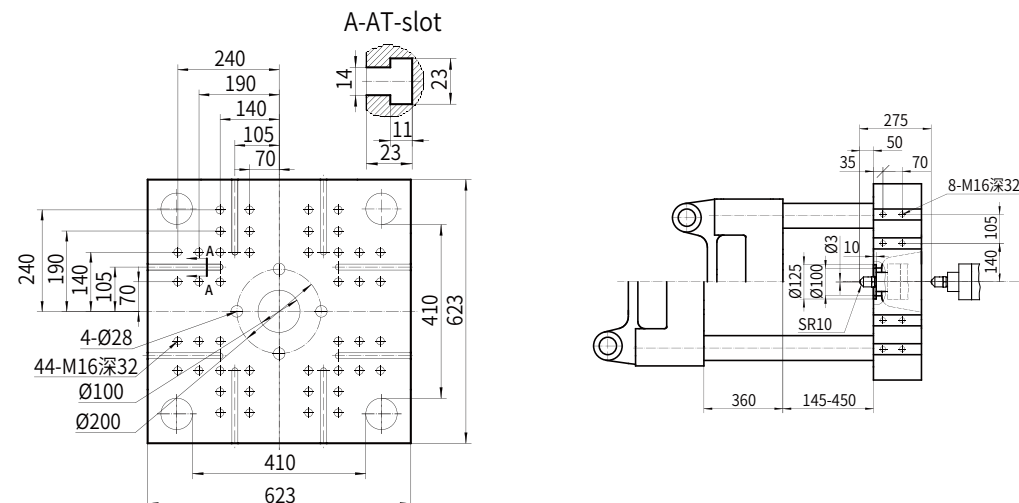

外形尺寸圖

Machine Dimensions

UN60A5

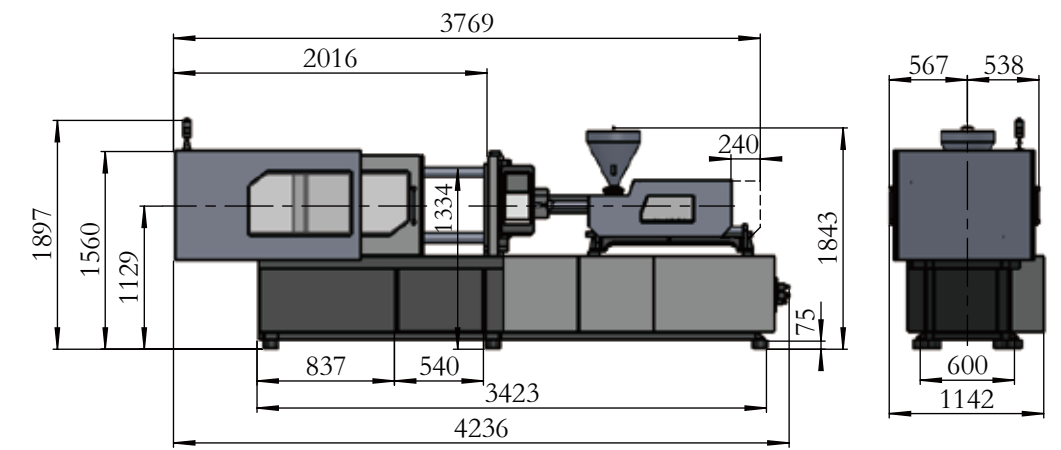

UN90A5

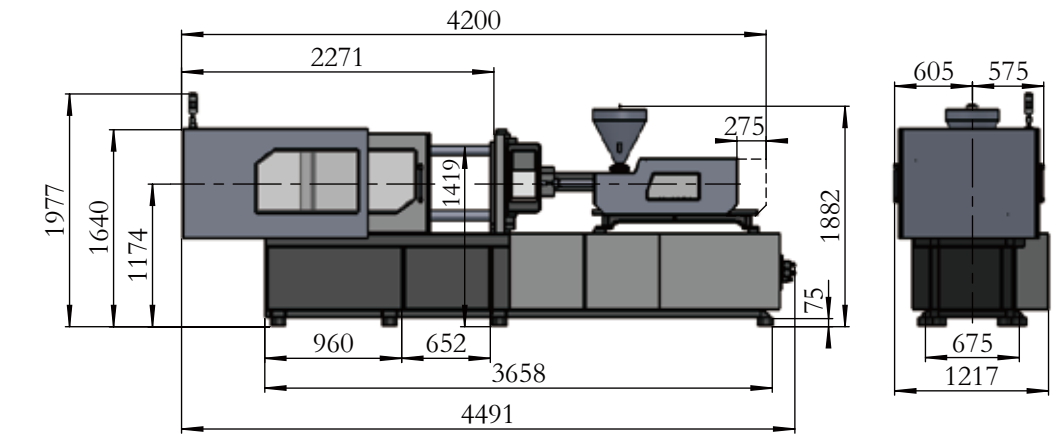

UN120A5

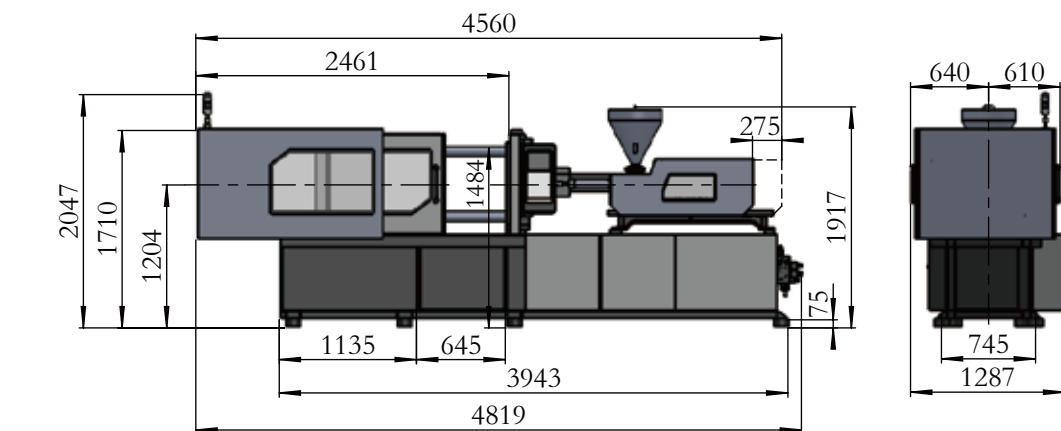

模板尺寸圖

Platen Dimensions

UN160A5

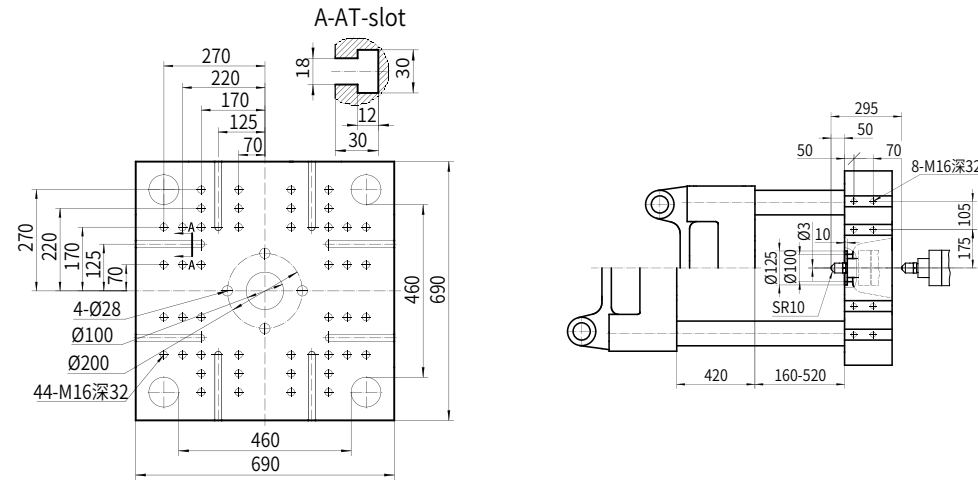

UN200A5

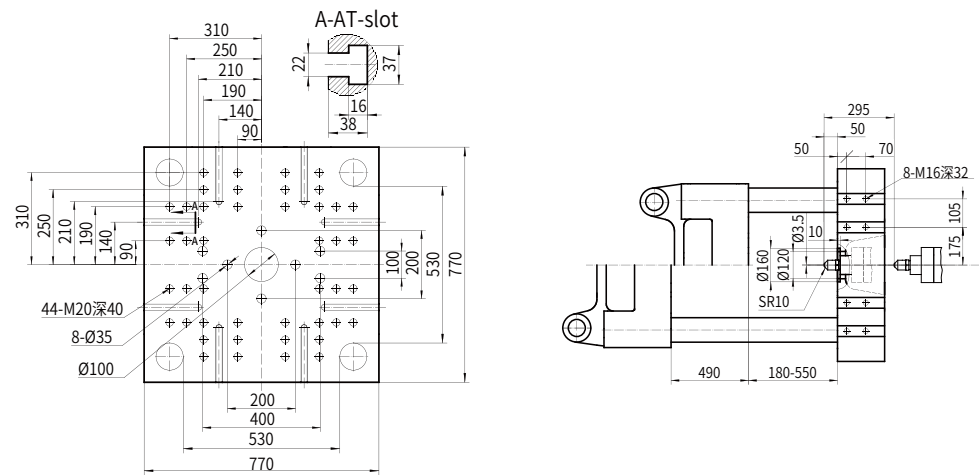

UN260A5

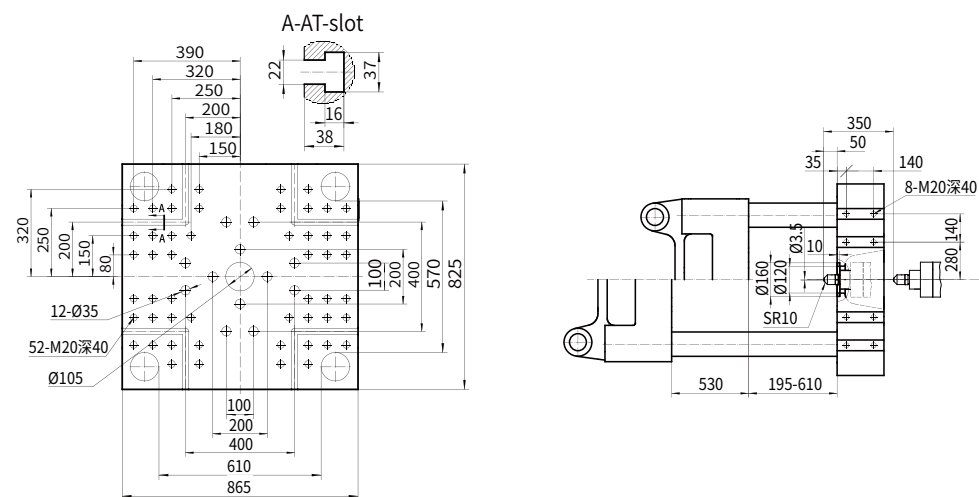

外形尺寸圖

Machine Dimensions

UN160A5

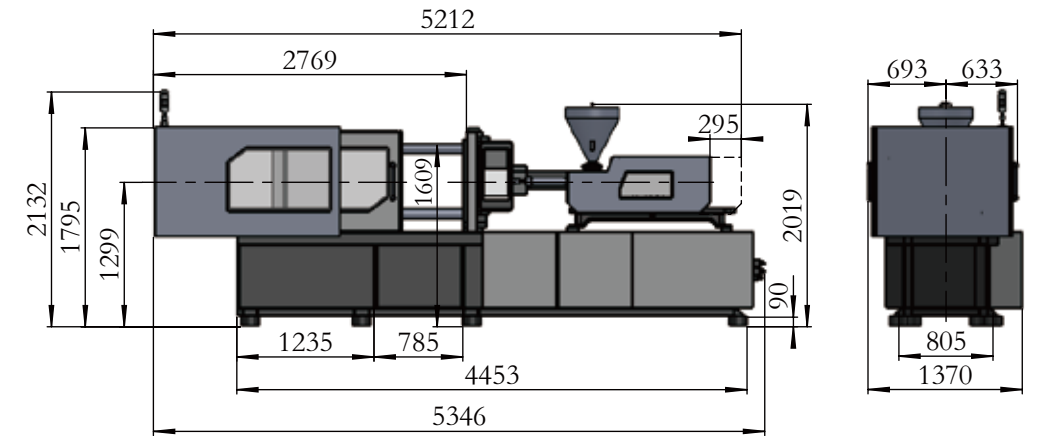

UN200A5

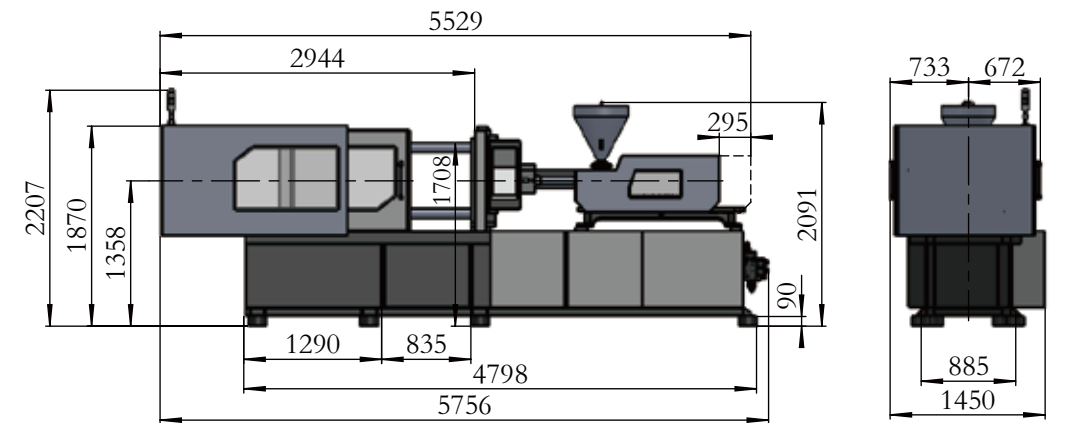

UN260A5

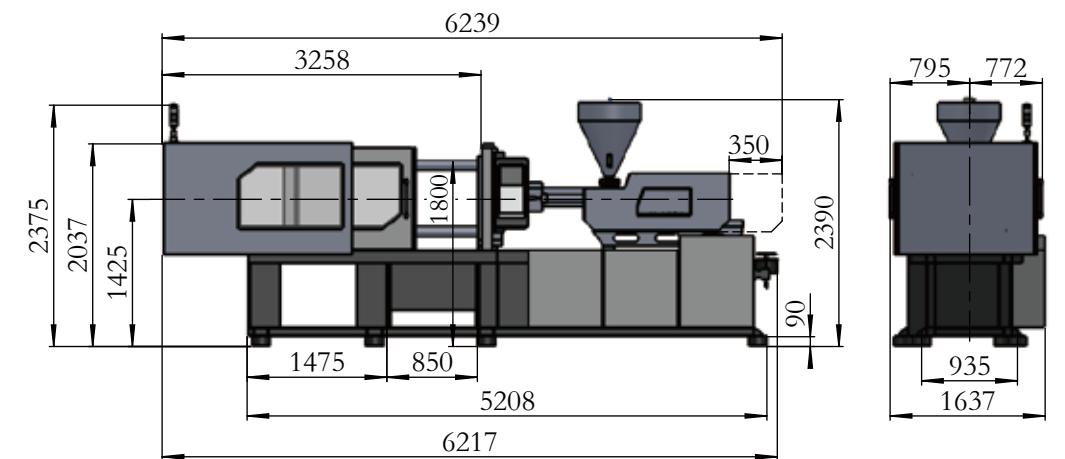

模板尺寸圖

Platen Dimensions

UN320A5

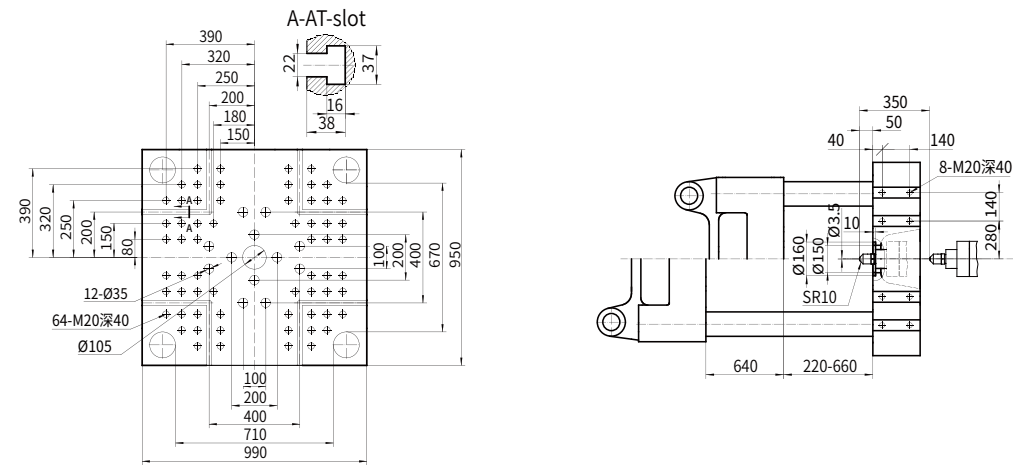

UN400A5

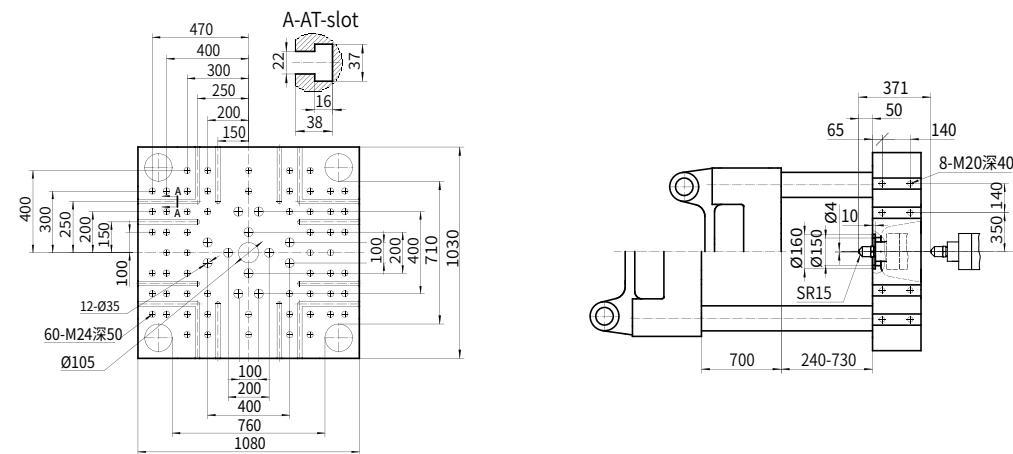

UN480A5

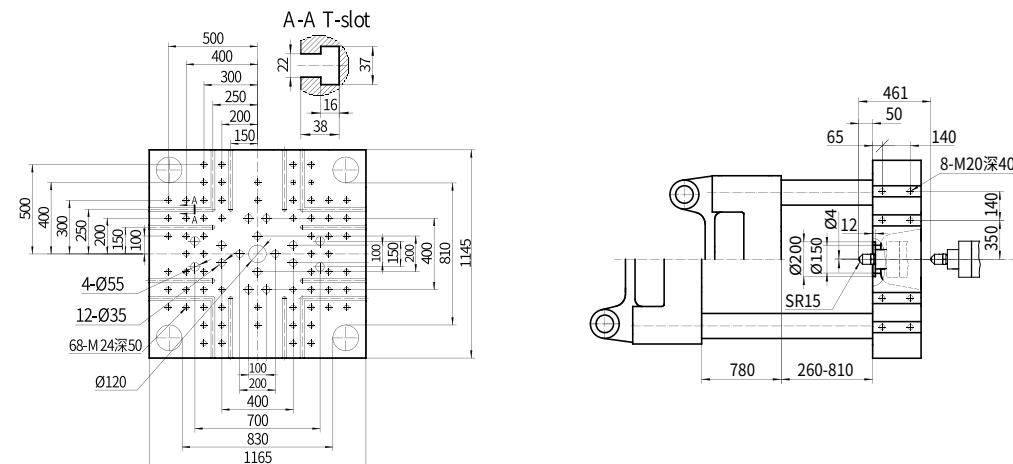

外形尺寸圖

Machine Dimensions

UN320A5

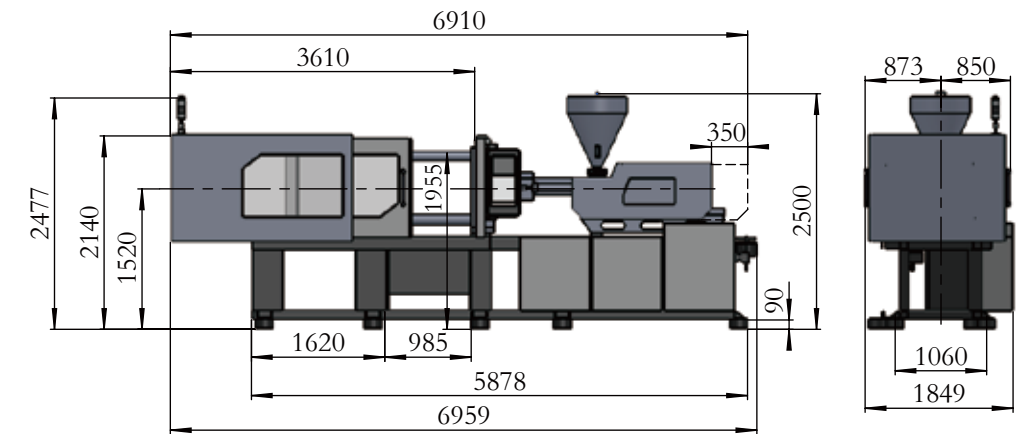

UN400A5

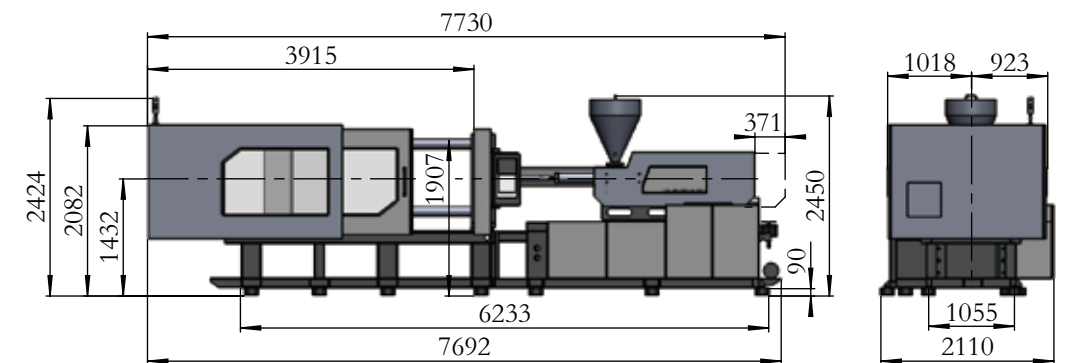

UN480A5

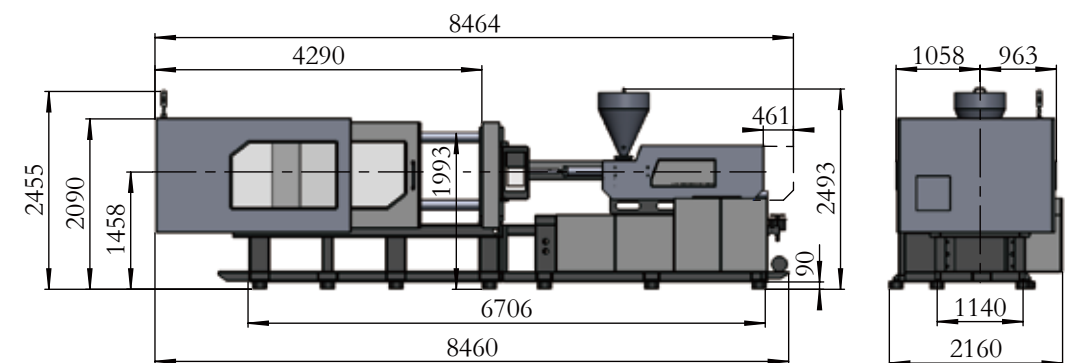

模板尺寸圖

Platen Dimensions

UN560A5

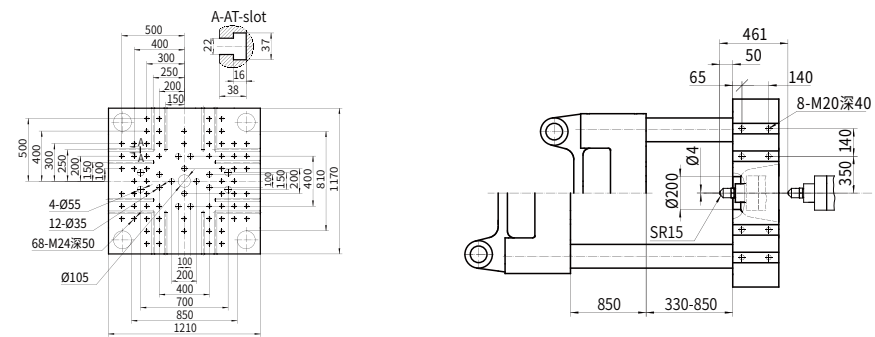

UN650A5

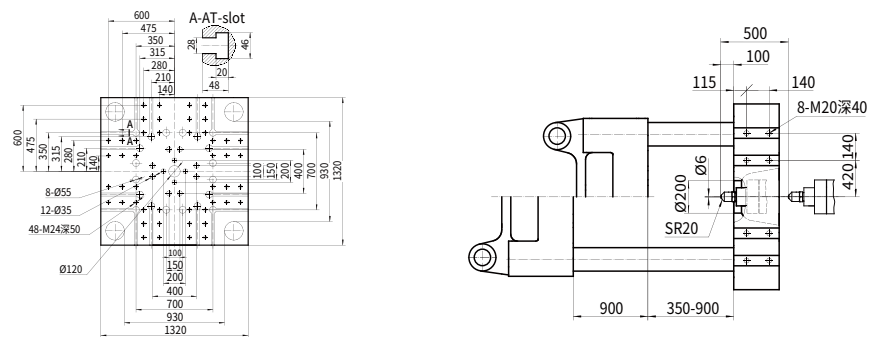

UN800A5

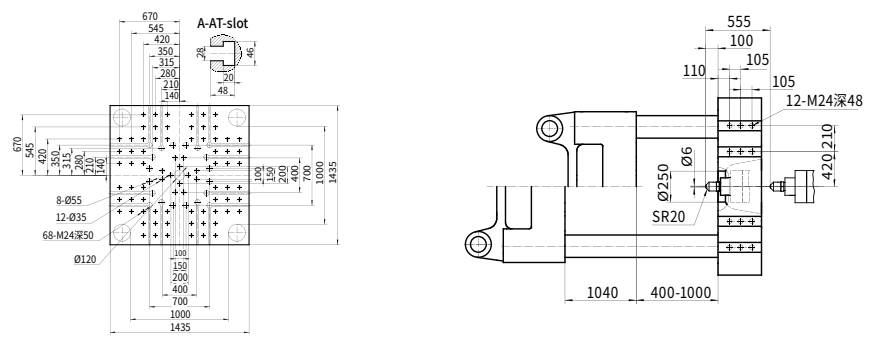

UN1000A5

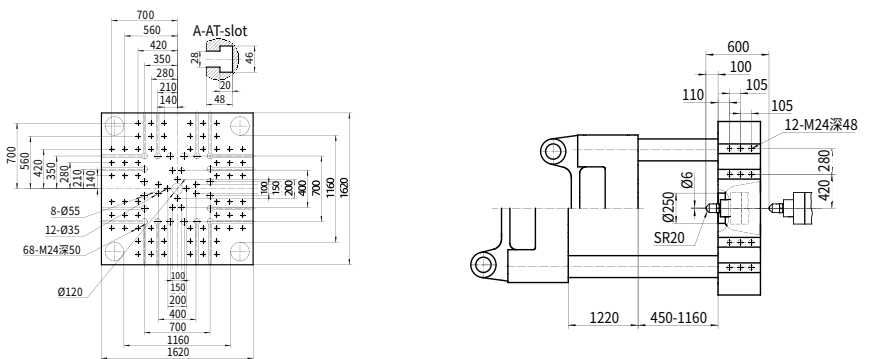

外形尺寸圖

Machine Dimensions

UN560A5

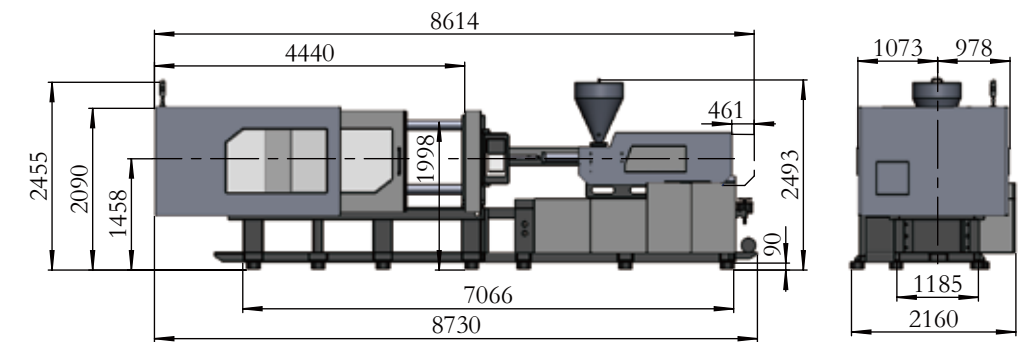

UN650A5

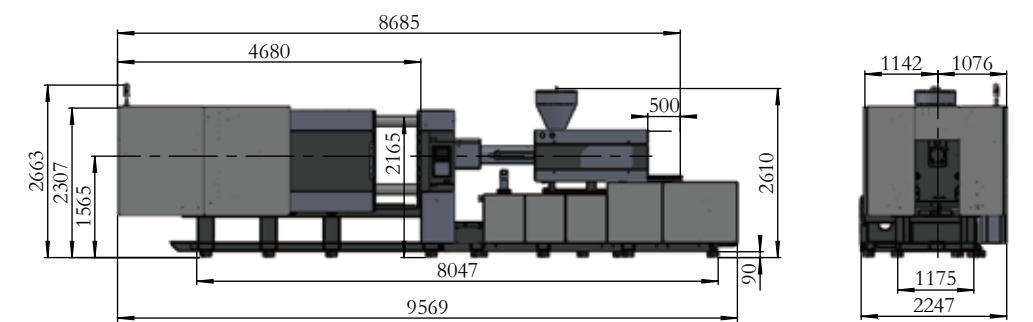

UN800A5

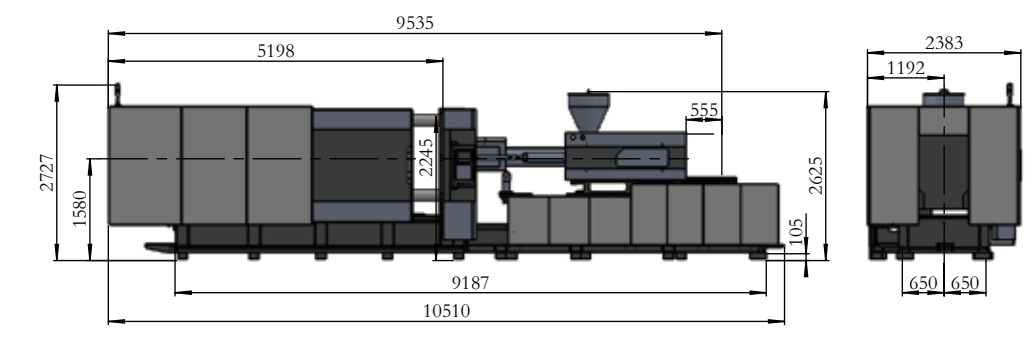

UN1000A5

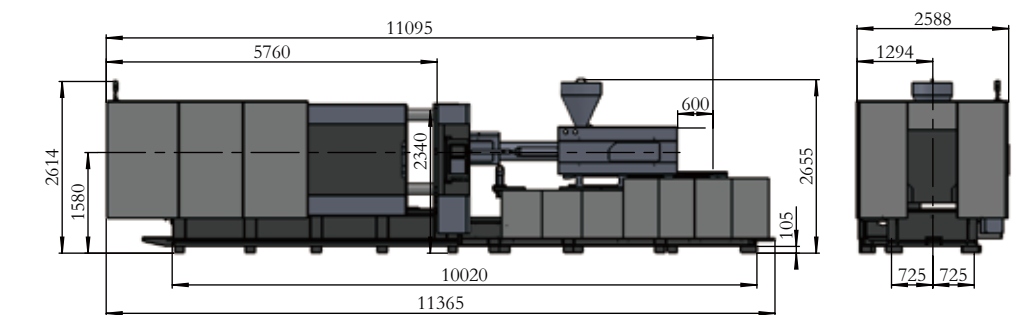

模板尺寸圖

Platen Dimensions

UN1400A5

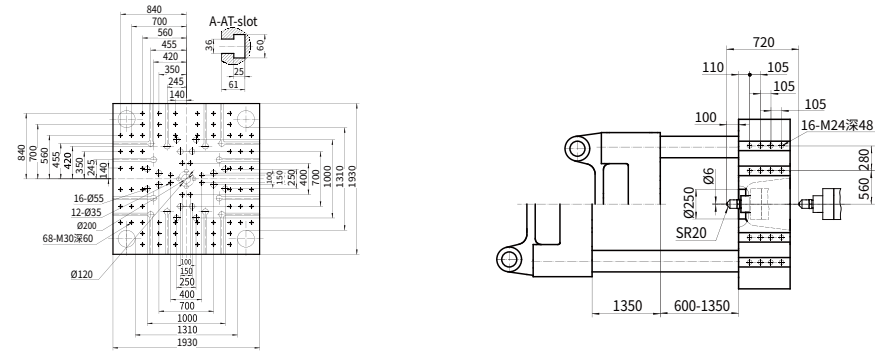

UN1800A5

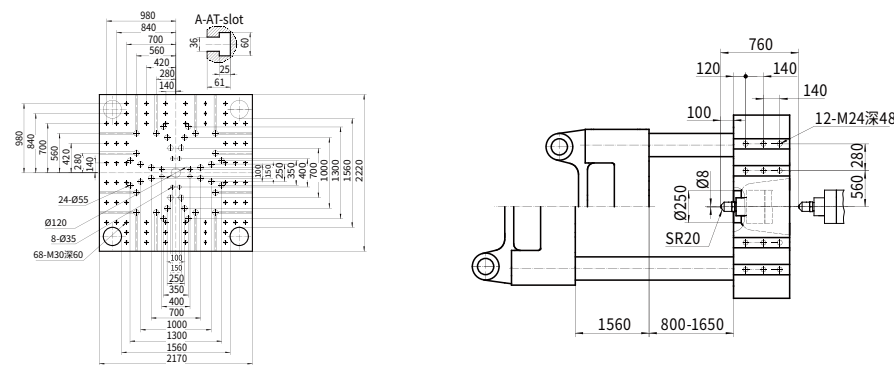

UN2200A5

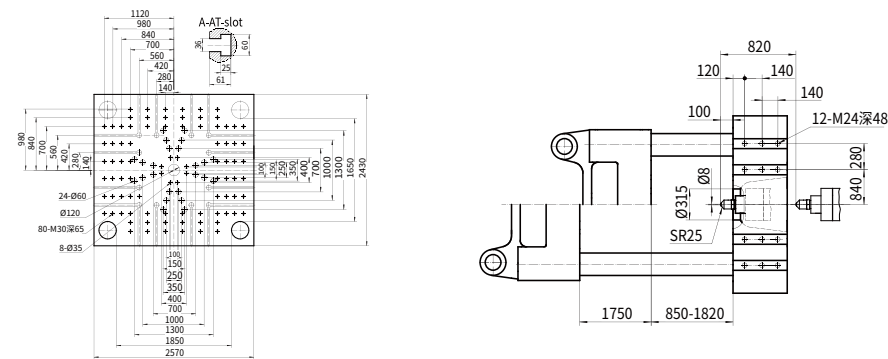

UN2600A5

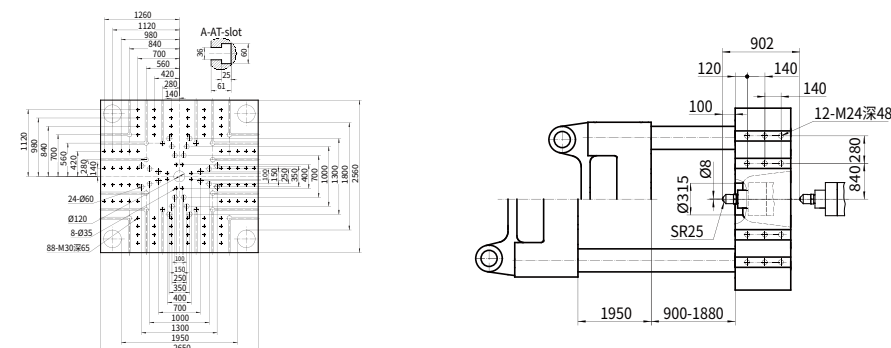

外形尺寸圖

Machine Dimensions

UN1400A5

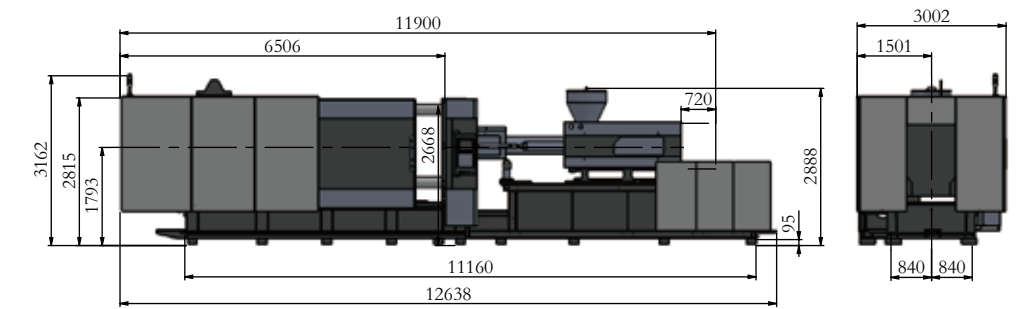

UN1800A5

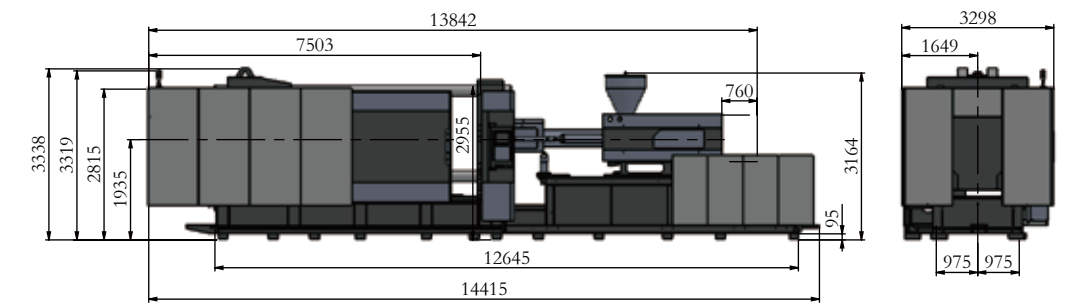

UN2200A5

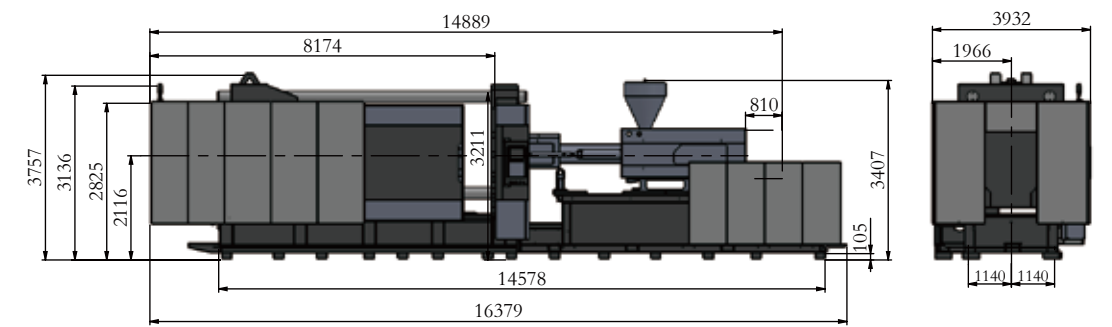

UN2600A5

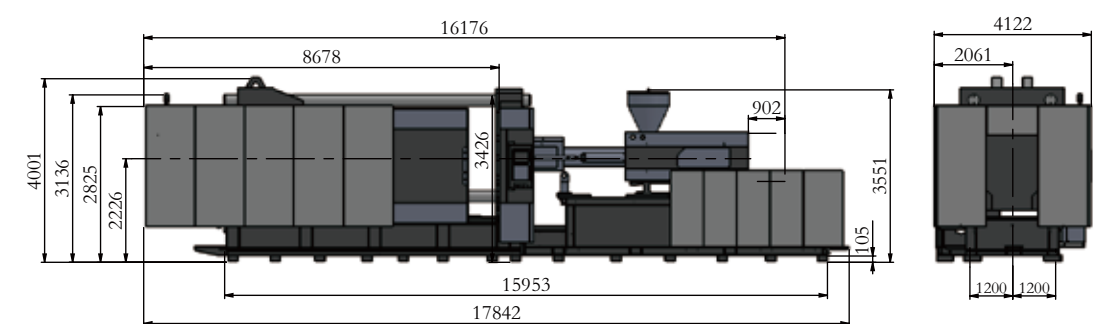

UN60~560A5 標配選配表

	標準配置	備選配置
射膠/熔膠部分		
整體式射台支架配線性導軌	●	
雙缸平衡注射系統	●	
低速大扭矩液壓馬達	●	
氮化合金鋼螺桿料筒	●	
料管節能環結構(專利設計)	●	
射嘴及料管多段PID溫度控制	●	
雙射移油缸	●	
全封閉式保溫罩/射嘴防護罩(不帶電氣保護)	●	
螺桿防冷開機功能	●	
自動清料功能	●	
熔膠前、後松退可選	●	
移動或滾動料斗裝置(60T-320T)	●	
熔膠三軸承傳動(260T以上)	●	
螺桿轉速檢測	●	
數控比例背壓	●	
專用料管組(電鍍、合金、PC、PMMA、PBT、PA等)		○
料筒風冷裝置		○
射嘴防護罩(帶電氣保護)		○
彈簧自鎖射嘴		○
加大注射行程或加大(減少)一級射膠結構		○
旋轉射台		○
陶瓷發熱圈(800T以上標配)		○
料筒保溫節能裝置(矽膠保溫、紅外線加熱)		○
鎖模部分		
精密電子尺控制鎖模/頂針行程/射膠行程	●	
鎖模三大板/機鉸採用QT500-7A高剛性球墨鑄鐵	●	
歐規機械手機械定位介面	●	
液壓驅動齒輪調模裝置	●	
機械/電氣雙重保護裝置	●	
免調節式機械安全鎖撞杆	●	
移動範本耐磨錳鋼帶軌道	●	
自動集中潤滑系統	●	
多種頂針控制功能可選	●	
低壓模具保護功能	●	
T型槽、碼模孔複合範本	●	
一鍵式自動調模功能	●	
頂針強制復位功能	●	
機門邊加裝防夾傷、緩衝條設計	●	
加裝特殊模具安裝孔		○
加裝模具隔熱板		○
加大頂出力、加大頂出行程		○
加大容模量		○
磁力範本		○
吊模架		○
液壓系統		
第三代伺服系統	●	
高精度即時旁路濾油器裝置	●	
低噪音節能型液壓回路	●	
進口名牌液壓控制閥	●	
進口名牌液壓密封件	●	

	標準配置	備選配置
差動快速合模裝置	●	
內置式冷卻器	●	
開模剎車油路設計	●	
油溫檢測及高溫報警	●	
外露高壓油管配防爆鏈	●	
全機標配一組帶閘抽芯介面	●	
多組運水裝置並配快速插頭	●	
變數泵系統		○
加大多級油泵、電機		○
加大多級熔膠馬達		○
同步頂出、抽芯、熔膠系統		○
高回應蓄能伺服注射系統		○
多組抽芯裝置		○
加裝液壓旋轉脫模裝置		○
控制系統		
料管加熱強制保護	●	
輸入、輸出檢視畫面	●	
自動保溫及自動加熱設定功能	●	
射膠轉保壓方式:時間/位置/時間+位置	●	
10.4" TFT真彩色LCD顯示幕	●	
240組大容量工藝參數存貯空間, USB存儲介面	●	
多種操作語言	●	
雙色報警燈	●	
所有電子尺、弱電開關、換向電磁閥線加套防水、防鼠咬波紋管	●	
可設置多級密碼保護, 操作面板帶鎖按鍵鑰匙	●	
前、後機門急停開關保護	●	
質量數據程序控制介面	●	
生產統計程序控制(SPC)即時清單介面	●	
預留吹風、抽芯、頂退回保護等多種介面	●	
3組/三相電源插座(2×32A+16A)或(32A+2×16A)	●	
同步射膠閘開信號	●	
鎖模力自動調整功能	●	
熱流道介面		○
氣動順序閥		○
電動旋轉脫模介面		○
吹氣帶閘裝置		○
氣輔注射裝置		○
中央(聯網)監控系統		○
前、後機門內光柵保護		○
電腦整機能耗顯示		○
更改電源電壓		○
其他配置		
說明書	●	
避震腳	●	
工具箱及工具一套, 精密篩檢程式濾芯一件	●	
不銹鋼料斗	●	
碼模夾		○
自動上料機		○
玻璃管冷卻流量計		○
乾燥機		○

Standard and Optional Features of UN60~560A5

	Standard	Optional
Injection Unit		
One-piece injection unit support with linear guides	●	
Parallel double-cylinder injection system	●	
Low-speed high-torque hydraulic motor	●	
Nitrided alloy-steel screw and barrel	●	
Energy-saving groove design of barrel(patented design)	●	
Multi-stage PID barrel temperature control	●	
Double-carriage cylinder	●	
Fully-closed heat retaining cover/ purge guard (without electrical protection)	●	
Cold start protection	●	
Automatic purging	●	
Selectable suck-back before or after plasticizing	●	
Movable or rolling hopper device (60T-320T)	●	
Three-bearing drive shaft (260T-2600T)	●	
Screw speed detection	●	
Proportional back pressure	●	
Dedicated barrel and screw assembly (electroplating, alloy, PC, PMMA, PBT, PA, etc.)		○
Barrel air-cooling device		○
Purge guard (with electrical protection)		○
Spring shut-off nozzle		○
Increased injection stroke or one-size larger(smaller) injection unit		○
Swivel injection uni		○
Ceramic heater band (standard on machines over 800T)		○
Barrel heat-retaining energy-saving device (silicone heat preservation, infrared heating)		○
Clamping Unit		
Precision transducer for clamping / ejector stroke control / injection stroke	●	
Clamping platens / toggles made of highly-rigid ductile iron QT500-7A	●	
EUROMAP-based robot mounting holes	●	
Hydraulic mold height adjustment device	●	
Mechanical / electrical safety devices	●	
Adjustment-free mechanical safety lock rod	●	
Wear-resistant manganese steel supporting tracks for movable platen	●	
Automatic centralized lubrication system	●	
Multiple ejector function settings	●	
Low-pressure mold protection	●	
Platen with T-slots and screw holes	●	
One-button automatic mold height adjustment	●	
Compulsory ejector-back function	●	
Safety edges for machine gates	●	
Special mold mounting hole		○
Mold thermal insulation plate		○
Increased ejector force and ejector stroke		○
Increased mold thickness		○
Magnetic platen		○
Mold lifting device		○
Hydraulic System		
Third-generation servo pump system	●	
High-precision bypass oil filter	●	
Automatic correction of system pressure and flow	●	
Brand-name hydraulic valve	●	
Brand-name hydraulic seal	●	

	Standard	Optional
Differential fast mold closing device	●	
built-in cooler	●	
Hydraulic circuit design of mold-open deceleration	●	
Automatic oil temperature detection and alarm	●	
Cable hose restraint for exposed HP hydraulic hose	●	
1 set of core puller interface	●	
Multi-channel cooling water devices with fast connectors	●	
Variable displacement pump system		○
Larger oil pump and motor		○
Larger plasticizing motor		○
Synchronized ejection, core pulling and plasticizing system		○
High-response servo injection system with accumulator		○
Multiple sets of core puller		○
Hydraulic unscrewing device		○
Control System		
Enhanced barrel heater protection	●	
Input/output inspection	●	
Automatic heat retaining and automatic heating setting	●	
Time / position / time + position controlled switchover from injection to holding	●	
10.4" TFT true color display	●	
240 sets of process parameters storage memory	●	
Multiple operating languages	●	
Two-color alarm light	●	
All transducers, weak-current switches and reversing solenoid valves enclosed by water-proof and rat-proof corrugated pipes	●	
Multi-level password security and key-locked operation panel	●	
Emergency stop buttons for front and rear safety gates	●	
PDP interface	●	
Statistical process control (SPC) interface	●	
Reserved interfaces for air blowing, core pulling, ejector back protection devices, etc.	●	
Three sets of 3-phase power socket (2×32A+16A)	●	
Synchronous injection valve open signal	●	
Automatic clamping force adjustment	●	
Hot runner interface		○
Pneumatic sequence valve		○
Interface for electric unscrewing interface		○
Air blow device		○
Air-assisted injection device		○
Central (networked) monitoring system		○
Protective light grid of safety gates		○
Display of overall energy consumption		○
Change of power supply voltage		○
Other		
Operation manual	●	
Leveling pad	●	
A tool kit and a precision filter element	●	
Stainless steel hopper	●	
Mold clamp		○
Auto loader		○
Glass-tube water flowmeter		○
Dryer		○

UN650~2600A5 標配選配表

	標準配置	備選配置
射膠/熔膠部分		
整體式射台支架配線性導軌	●	
氮化合金鋼螺桿料筒	●	
料管節能環結構(專利設計)	●	
射嘴及料管多段PID溫度控制	●	
雙射移油缸	●	
全封閉式保溫罩/射嘴防護罩(不帶電氣保護)	●	
螺桿防冷開機功能	●	
自動清料功能	●	
熔膠前、後松退可選	●	
射膠、熔膠故障自動檢測	●	
非接觸式精密電子尺控制射膠/熔膠行程	●	
注射速度、壓力、位置6段設定	●	
保壓速度、壓力、時間5段設定	●	
儲料速度、壓力、時間4段設定	●	
螺桿轉速檢測	●	
數控比例背壓	●	
鍍硬鉻螺桿組件		○
雙金屬螺桿元件		○
專用螺桿組件		○
料筒風冷裝置		○
射嘴防護罩(帶電氣保護)		○
彈簧自鎖射嘴		○
乾燥料斗		○
上料平臺		○
鎖模部分		
精密電子尺控制鎖模/頂針行程	●	
鎖模三大板/機鉸採用QT500-7A高剛性球墨鑄鐵	●	
歐規機械手機械定位介面	●	
電腦控制兩段頂出前進/後退動作	●	
液壓驅動齒輪調模裝置	●	
免調節式機械安全鎖撞杆	●	
機械/電氣/液壓三重保護裝置	●	
移動範本耐磨錳鋼帶軌道	●	
自動集中潤滑系統	●	
多種頂針控制功能可選	●	
T型槽、碼模孔複合範本	●	
低壓模具保護功能	●	
機門邊加裝防夾傷、緩衝條設計	●	
加裝特殊模具安裝孔		○
加裝模具隔熱板		○
加大頂出行程		○
加大容模量		○
磁力範本		○
液壓系統		
第三代伺服系統	●	
高精度即時旁路濾油器裝置	●	
系統壓力流量自動校正	●	
進口名牌液壓控制閥	●	
進口名牌液壓密封件	●	
油溫檢測及高溫報警	●	

	標準配置	備選配置
低噪音液壓系統	●	
液壓油冷卻裝置	●	
兩組液壓抽芯(頭、二板各一組)	●	
兩組抽芯介面(頭、二板各一組)	●	
多組運水裝置並配快速插頭	●	
高性能閉環比例變數泵系統		○
加大一級油泵電機		○
旋轉脫模裝置		○
獨立油溫控制系統		○
高回應蓄能伺服注射系統		○
高回應伺服注射系統		○
高回應伺服開合模系統		○
同步頂出裝置		○
加大油冷卻器		○
控制系統		
料管加熱強制保護	●	
輸入、輸出檢視畫面	●	
自動保溫及自動加熱設定功能	●	
射膠轉保壓方式:時間/位置/時間+位置	●	
10.4" TFT真彩色LCD顯示幕	●	
100組工模參數存貯空間	●	
多種操作語言	●	
雙色報警燈	●	
動作斜率的獨立調整	●	
兩組液壓抽芯/旋轉脫模電氣介面	●	
工藝參數鎖定功能	●	
機械手介面	●	
前、後機門急停開關保護	●	
生產統計程序控制(SPC)即時清單介面	●	
3組/三相電源插座(2x32A+16A)	●	
同步射膠開閉信號	●	
鎖模力自動調整功能	●	
熱流道介面		○
電動旋轉脫模介面		○
氣輔注射裝置		○
工作燈/單色或多色報警燈		○
單相/三相電源插座		○
工模吹風		○
電動旋轉脫模裝置		○
更改電源電壓		○
其它配置		
說明書	●	
可調防震避震腳	●	
工具箱及工具一套,精密篩檢程式濾芯一件	●	
不銹鋼料斗	●	
碼模夾		○
自動上料機		○
玻璃管冷卻流量計		○
除濕機		○
模具溫度控制器		○

Standard and Optional Features of UN650~2600A5

	Standard	Optional
Injection Unit		
One-piece injection unit support with linear guides	●	
Nitrided alloy-steel screw and barrel	●	
Energy-saving groove design of barrel (patented design)	●	
Multi-stage PID barrel temperature control	●	
Double-carriage cylinder	●	
Fully-closed heat retaining cover/ purge guard (without electrical protection)	●	
Cold start protection	●	
Automatic purging	●	
Selectable suck-back before or after plasticizing	●	
Automatic detection of injection and plasticizing faults	●	
Precision transducer for injection / plasticizing stroke control	●	
6-stage injection speed / pressure / position control	●	
5-stage holding pressure speed / pressure / time control	●	
4-stage plasticizing speed / pressure / time control	●	
Screw speed detection	●	
Proportional back pressure	●	
Hard chrome plated screw component		○
Bi-metallic barrel unit		○
Dedicated screw assembly		○
Barrel air-cooling device		○
Purge guard (with electrical protection)		○
Spring shut-off nozzle		○
Hopper dryer		○
Hopper loading platform		○
Clamping Unit		
Precision transducer for clamping / ejector stroke control	●	
Clamping platens / toggles made of highly-rigid ductile iron QT500-7A	●	
EUROMAP-based robot mounting holes	●	
Computer controlled two-stage ejection forward/backward movement	●	
Hydraulic mold height adjustment device	●	
Adjustment-free mechanical safety lock rod	●	
Mechanical / electrical / hydraulic safety devices	●	
Wear-resistant manganese steel supporting tracks for movable platen	●	
Automatic centralized lubrication system	●	
Multiple ejector function settings	●	
Platen with T-slots and screw holes	●	
Low-pressure mold protection	●	
Safety edges for machine gates	●	
Special mold mounting hole		○
Mold thermal insulation plate		○
Increased ejector stroke		○
Increased mold thickness		○
Magnetic platen		○
Hydraulic System		
Third-generation servo pump system	●	
High-precision bypass oil filter	●	
Automatic correction of system pressure and flow	●	
Brand-name hydraulic valve	●	
Brand-name hydraulic seal	●	
Automatic oil temperature detection and alarm	●	

	Standard	Optional
Low noise hydraulic system	●	
Hydraulic oil cooling device	●	
2 sets of hydraulic core puller (one each for fixed platen and movable platen)	●	
2 sets of core puller interface (one each for fixed platen and movable platen)	●	
Multi-channel cooling water devices with fast connectors	●	
Variable displacement pump system		○
Larger oil pump and motor		○
Hydraulic unscrewing device		○
Independent oil temperature control system		○
High-response servo injection system with accumulator		○
Highly-responsive servo injection system		○
High-response servo mold opening and closing system		○
Synchronized ejection unit		○
Enlarged oil cooler		○
Control System		
Enhanced barrel heater protection	●	
Input/output inspection	●	
Automatic heat retaining and automatic heating setting	●	
Time / position / time + position controlled switchover from injection to holding	●	
10.4" TFT true color display	●	
100 sets of process parameters storage memory	●	
Multiple operating languages	●	
Two-color alarm light	●	
Independent motion slope adjustment	●	
Two sets of core pulling / unscrewing electrical interface	●	
Process parameter locking feature	●	
Robot interface	●	
Emergency stop buttons for front and rear safety gates	●	
Statistical process control (SPC) interface	●	
Three sets of 3-phase power socket (2x32A+16A)	●	
Synchronous injection valve open signal	●	
Automatic clamping force adjustment	●	
Hot runner interface		○
Interface for electric unscrewing interface		○
Air-assisted injection device		○
Working light/ one- or three-color alarm light		○
Single-phase / three-phase power socket		○
Air blow device		○
Interface for electric unscrewing device		○
Change of power supply voltage		○
Other		
Operation manual	●	
Leveling pad	●	
A tool kit and a precision filter element	●	
Stainless steel hopper	●	
Mold clamp		○
Auto loader		○
Glass-tube water flowmeter		○
Dehumidifier		○
Mold temperature controller		○

銷售服務網絡

SALES AND SERVICE NETWORK

